



**REACH**  
GARAGE EQUIPMENT



PL-E30/E35/E30L/E35L

## DOUBLE-LEVEL SCISSOR LIFT

USER'S MANUAL V1.2 202005

INSTRUCTION & MAINTENANCE MANUAL



READ THIS ENTIRE MANUAL CAREFULLY AND COMPLETELY  
BEFORE INSTALLATION OR OPERATION OF THE LIFT

## SCISSOR LIFT INSTRUCTION MANUAL

INDEX	PAGE
1.Packing, transport and storage.....	- 3 -
1.1 Packing:.....	- 3 -
1.2 Transport: .....	- 4 -
1.3 Storage: .....	- 4 -
2.Manual introduction .....	- 4 -
3.Description of the machine .....	- 5 -
3.1 Machine Application .....	- 5 -
3.2 Structure Features.....	- 5 -
3.3 Equipment .....	- 6 -
3.4 Frame.....	- 6 -
3.5 Control box.....	- 6 -
4. Specifications .....	- 7 -
4.1 Main technical parameter .....	- 7 -
4.2 External dimension drawing.....	- 8 -
4.3 Types of vehicles suitable for .....	- 9 -
5. Safety notes .....	- 10 -
6. Installation.....	- 13 -
7. Adjustment .....	- 18 -
8. Operation.....	- 21 -
9. Maintenance and care.....	- 23 -
10. Trouble shooting table.....	- 25 -
11. Hydraulic pressure elements diagram.....	- 26 -
12. Oil hose connection diagram.....	- 27 -
13. Circuit diagram.....	- 28 -
14. Pneumatic drawing .....	- 30 -
15.Explosion drawing.....	- 31 -
16.Accessories Packing List.....	- 39 -

# 1.Packing, transport and storage



All packing, lifting, handling, transport and unpacking operations are to be performed exclusively by expert personnel.

## 1.1.Packing

Standard equipment

Accessory box (4# CTN), main and sub Platform(1 # 、 2# CTN), control box (3# CTN).

### Packing List

NO.	Name	Accessory name and quantity
1	Lift Platform	Main Platform 1 piece
2	Lift Platform	Sub Platform 1 piece
3	Control Box	1 set
4	Accessory box	1 set(details are in the accessories packing list)

Table 1

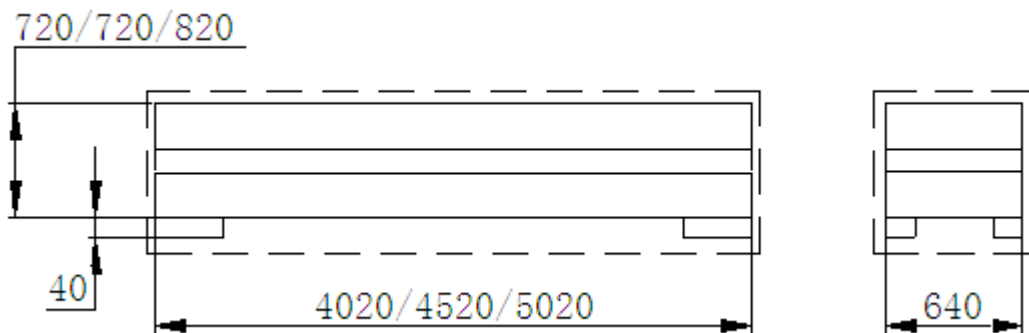

3.5T: 4020x640x720

4.5T: 4520x640x720

5.5T: 5020x640x820

Picture 1(Packing dimension picture)

## 1.2. Transport



**Packing can be lifted or moved by lift trucks, cranes or bridge cranes. In case of slinging, a second person must always take care of the load, in order to avoid dangerous oscillations.**

During loading and unloading operation, goods must be handled by vehicles or ships.

At the arrival of the goods, verify that all items specified in the delivery notes are included. In case of missing parts possible defects or damage may due to transport operations.

If finding missing parts, possible defects or damage due to transport, one should examine damaged cartons according to <<Accessories Packing List.>> to verify the condition of damaged goods and missing parts, also the person in charge or the carrier must be immediately informed.



**The machine is heavy goods! Don't take manpower load and unload and transporting way into consideration, the safety of working is important.**

Furthermore, during loading and unloading operation goods must be handled as shown in the picture. (Picture 2)

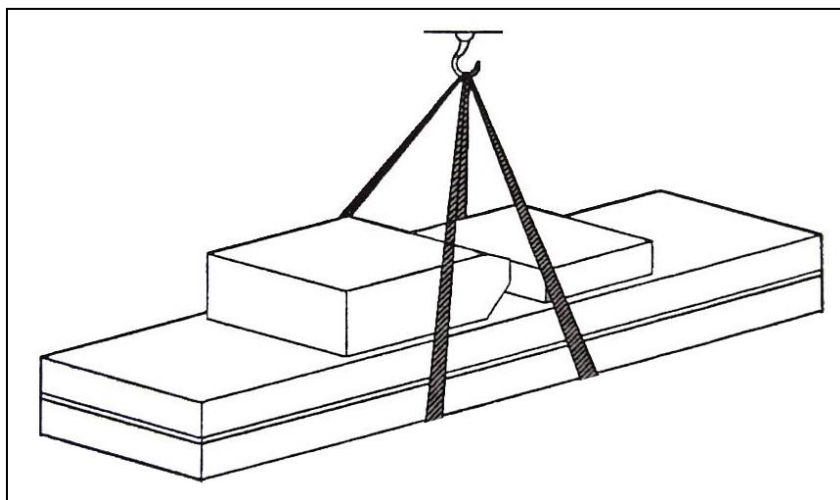

**Picture 2 (Goods-lifted)**

## 1.3. Storage

-The machine equipment should be stocked in the warehouse, if stocked outside should do the disposal well of waterproof.

-Use box truck in the process of transport, use container storage when shipping.

-The control box should be placed perpendicularly during the transport; and prevent other goods from extrusion.

-The temperature for machine storage : -25°C-- 55°C

## 2.Manual introduction



**This manual has been prepared for workshop personnel expert in the use of the lift operator and technicians responsible for routine maintenance fitter.**

Workers should read the <<Instruction & Maintenance Manual>> carefully before carrying out any operation with the lift. This manual contains important information regarding:

- The personal safety of operators and maintenance workers.
- Lift safety.
- The safety of lifted vehicles.



Several tips should be done by the operator as follow:

- 1.Well conserving the manual. Manufacturer owns the right to make little change for the manual owing to the improvement of technology.
- 2.Good disposal the used oil.
- 3.The machine must be demolished by authorized technicians, just like for assembling

## 3.Description of the machine

### 3.1.Machine Application



Double-level scissor lift can lift each kind of vehicle whose weight is less than 3500kg /4500kg /5500kg, suitable for use in four wheel alignment, vehicle tests, maintenance and caring for automobiles, which is particularly suitable for use in the basement or on the floor, without construction and hole.



**Lifts are designed and built to lift vehicles and hold them in the elevated position in an enclosed workshop. All other uses of the lifts are unauthorized. In particular, the lifts are not suitable for:**

- Washing spray work;
- Use in outdoors;
- Creating raised platforms for personnel or lifting personnel;
- Use as a press for crushing purposes;
- Use as elevator;
- Vehicle with severely tilted or bent frame, or with deformed wheels.



The manufacturer is not liable for any injury to persons or damage to vehicles and other property caused by the incorrect and unauthorized use of the lifts.

### 3.2.Structure Features

- Use hidden and thin scissor structure, dispense with construction and ground hole, the occupation is small
- Independent control box, low-voltage controlling, good security
- Same hydraulic cubage and in-phase cylinder, the synchronization of platform
- With hydraulic lock and mechanical dual-gear safety-claw lock double safety device, automatically open when lowering. Lock operation can has the safety-claw located, adversely, safe and reliable.
- Own protection of safety valve and burst-proof equipment for hydraulic failure and over loading. So when the oil pipe bursts, the machine will not fall quickly.
- Sliding blocks adopt oil free super-wearable materials.
- Use high quality hydraulic or electric element parts made in Italy, Germany, Japan and so on.

- The level of the lift can be adjusted in high precision to suit for various kinds of high-precision four-wheel alignment.
- Adjustable second-lifting platform length is suitable for various chassis of automobile.

**Safety lock structure**

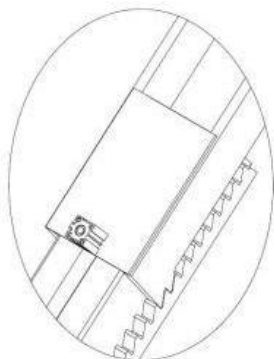

**Picture 3**

**3.3.Equipment**

- Machine basement (The position and space of equipment installation)
- Machine frame (The main structure of lift and insurance institution )
- Control box (Machine-controlled part)

**3.4.Frame**

Make of base, steel connecting rod, main lifting platform hydraulic oil cylinder and loading dock board.

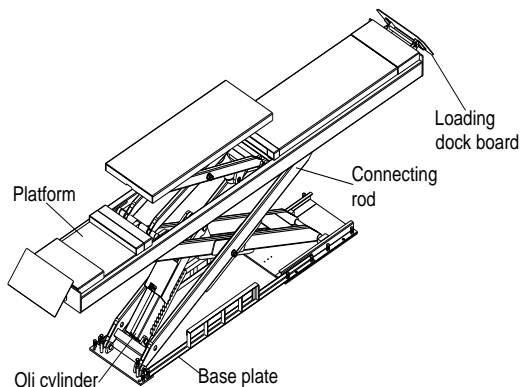

**Picture 4**

**3.5.Control box**

Under the control box is hydraulic oil tank and hydraulic pump, valve and other control system. On the control box is electrical system.

Function of each valve on the power unit	
Name	Function
Gear pump	Extract hydraulic oil and provide high pressure.
Connecting block	Connect the motor and the gear pump.
Motor	Provide power for the gear pump.
Overflow valve	Adjust oil pressure.

Pressure-compensated valve	Control the speed of falling.
Lowering solenoid valve	Control flow of the hydraulic oil.
One-way valve	Control the one-way flow of hydraulic oil.
Ball valve	Debugging and control the returned oil.

Table 2

## 4. Specifications

### 4.1 Main technical parameter

Machine type	3.5T	4.5T	5.5T
Drive	Electrical hydraulic		
Lifting capacity	3500kg	4500kg	5500kg
Main machine lift height	1850mm		
Sub machine lift height	450mm		
Platform initial height	330mm		380mm
Main machine platform length	4000mm	4500mm	5000mm
Sub machine platform length	1470--1610mm		1630--1770mm
Platform width	620mm		
Main machine lifting time	≤55s	≤55s	≤55s
Main machine descent time	≤55s	≤55s	≤55s
Sub machine lifting time	≤20s	≤20s	≤25s
Sub machine descent time	≤20s	≤20s	≤25s
Whole machine length	4500mm	5000mm	5500mm
Whole machine width	2040-2140mm		
Power supply	3/N/PE~380V, 50Hz, 16A		
Whole machine power	2.2kW		
Hydraulic oil	18L corresponds to wearable hydraulic oil		
air pressure	6-8kgf/cm <sup>2</sup>		
Working temperature	5-40°C		
Working humidity	30-95%		
Noisy	≤70dB		
Storage temperature	-25°C~55°C		

Table 3

**Requirements**

- Portland cement with strength grade above C20, the period of desiccation is 15 days
- Clean the basic layer, thickness of concrete $\geq$ 150mm, the levelness of whole length $\leq$ 5mm

**Supply at the same time**

- Connect to the power supply jack of control box (400V)
- Connect to the compressed air-entering pipe of control box ( $\phi 8 \times 5\text{mm}$ )

**4.2 External dimension drawing**

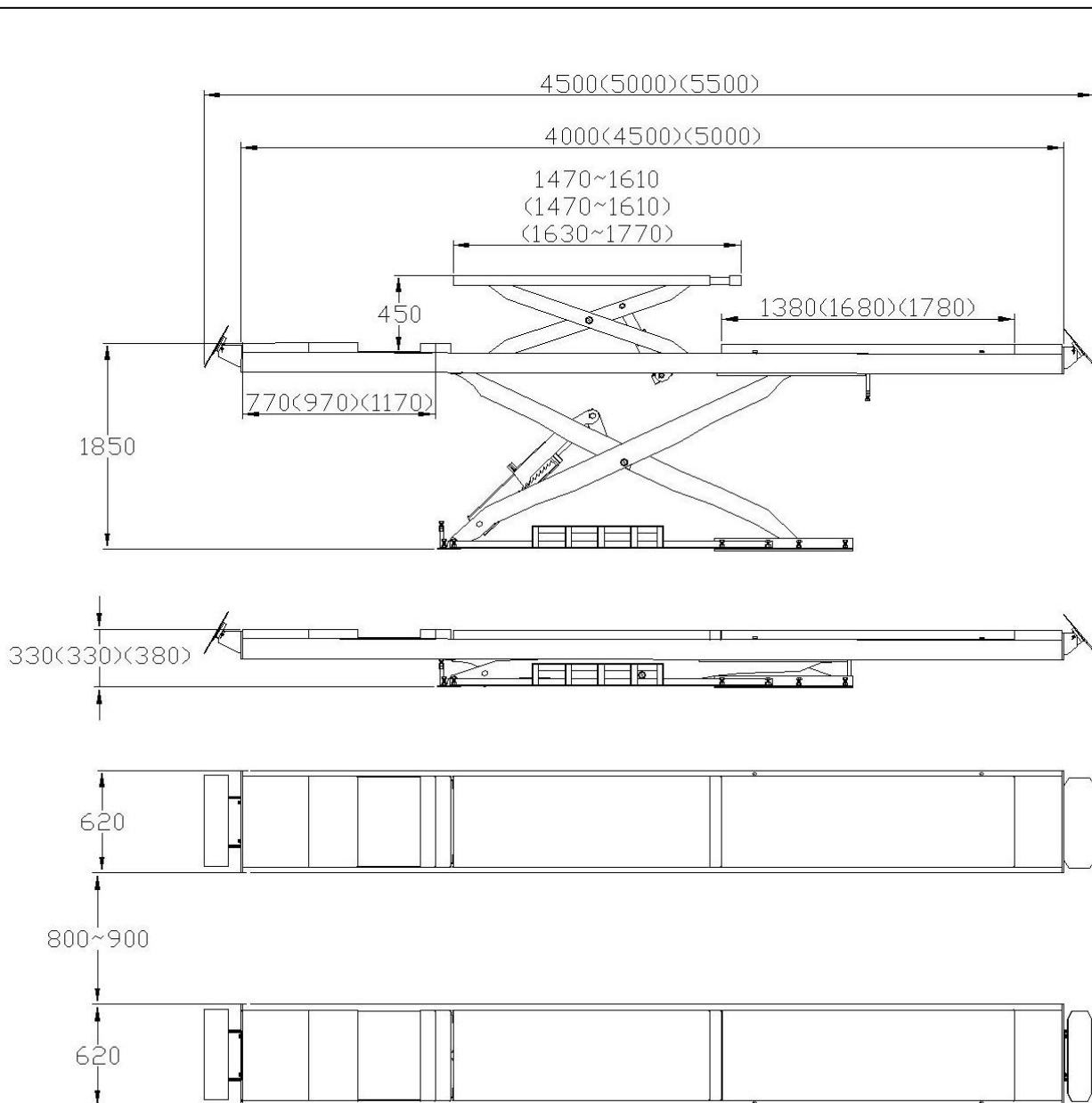

Picture 5 (Lift dimension picture)



### 4.3. Types of vehicles suitable for (For reference only)

This lift is suitable for virtually all vehicles with total weight and with dimensions not exceeding the below data. Maximum weight not exceed than 3500kg/4500kg/5500kg

#### The max dimension of vehicle:

The following diagrams illustrate criteria used to define the operating limits of the lift.

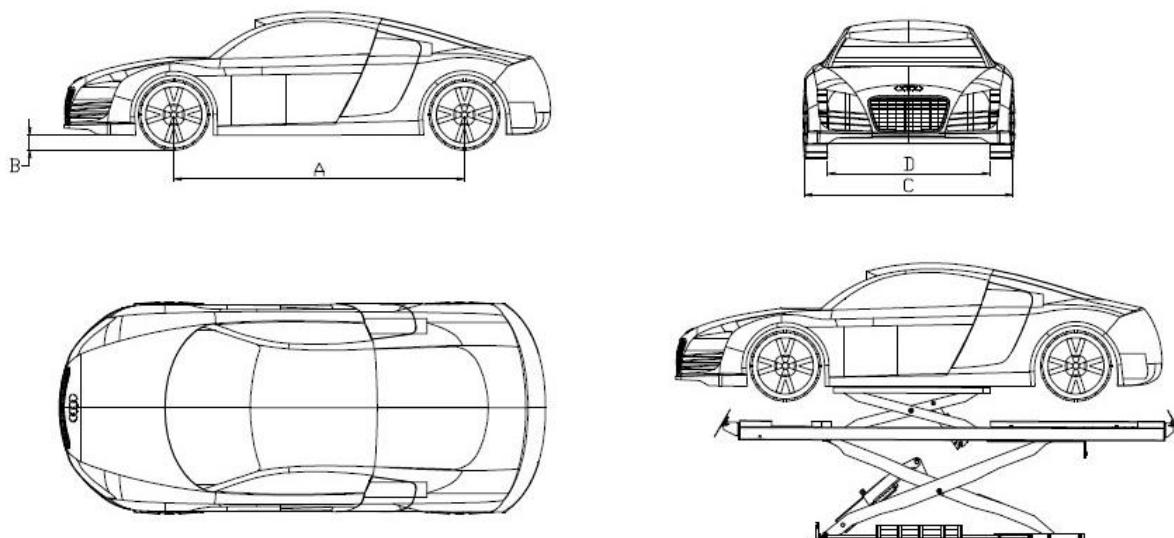

Picture 6

	3.5T/4.5T		5.5T	
	Min	Max.	Min	Max.
A	1900	3500/4000	2100	4500
B	100		100	
C		1900		1900
D	900		900	



The lower parts of the chassis could interfere with structural parts of the lift. Take particular parts of the sports-car.

The lift will also handle customized or non-standard vehicles provided they are within the maximum specified carrying capacity.

Also the personnel safety zone must be defined in relation to vehicle with unusual dimensions.

Do not use the lift without protection devices or with the protection devices inhibited.

Failure to comply with this regulation can cause serious injury to persons, and irreparable damage to the lift and the vehicle being lifted.

## 5. Safety notes

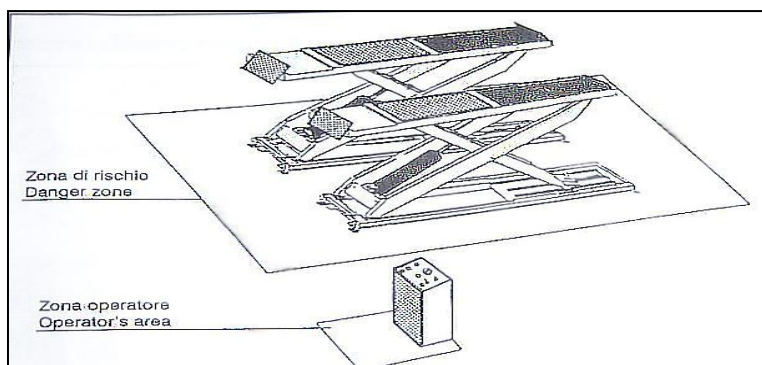

Picture 7



### General precautions

The operator and the maintenance fitter are required to observe the prescriptions of safety regulation in force in the country of installation of the lift.

Furthermore, the operator and maintenance fitter must:

- Always work in the stations specified and illustrated in this manual;
- Never remove or deactivate the guards and mechanical, electrical, or other types of safety devices;
- Read the safety notices placed on the machine and the safety information in this manual.



**In the manual all safety notices are shown as follows:**

**Warning:** indicates following operations that are unsafe and can cause minor injury to persons and damage the lift, the vehicle or other property.



**Risk of electric shock:** a specific safety notice placed on the lift in areas where the risk of electric shock is particularly high.



### Risk and protection devices

For optimal personal safety and safety of vehicles, observe the following regulations:

- Do not enter the safety and safety of vehicles is being lifted. (**Picture 7**)
- Be sure to lift only approved vehicles, never exceed the specified carrying capacity, maximum height, and projection (vehicle length and width);
- Make sure that there is no person on the platforms during up and down movements and during standing.

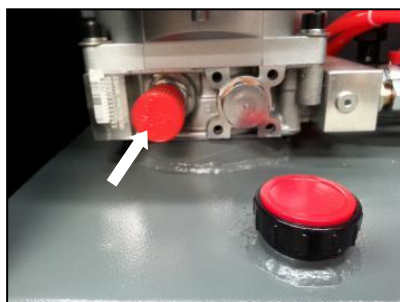

Picture 8

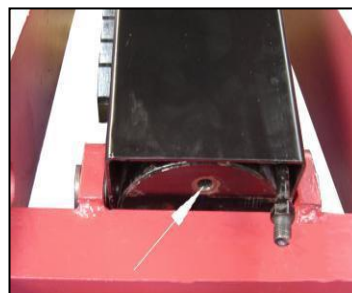

Picture 9



**General risks for lifting or descent**

The following safety equipments are used to protect over loading or the possibility of engine failure. In the condition of over loading, the over-falling valve will open and directly return oil to the oil tank. (See **Picture 8**)

Each bottom of oil cylinder is equipped with antiknock and locked valve. When the oil pipe is burst in the circuit of hydraulic pressure, the relevant antiknock and locked valve will work and limit the speediness of platform. (**Picture 9**)

Safety tooth and gear module are parts which guarantee the safety of personnel beneath the machine in failure condition of other protections.

So make sure the integrity of gear module and that the safety tooth has occluded completely. (**Picture 10**) There is nothing abnormal should be left on the safety modules to prevent safety gear from occlude normally.

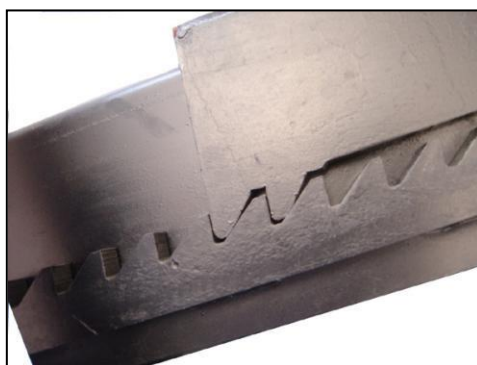

**Picture 10**



**Risk for extrusion**

During up and down operations, personnel leave the said area without following the rule and instruction. During up and down operations, no person is admitted to work beneath the movable parts of the lift, should work in the safe zone. (**Picture 11**)

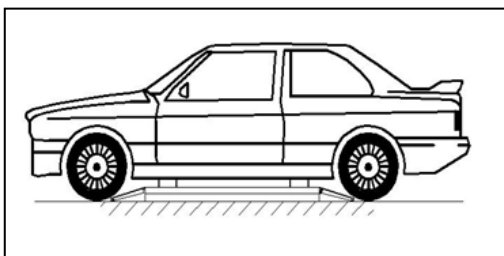

**Picture 11**



**Risk of impact**

Before the operator begins up and down movements, make sure that there are no personnel inside the danger zone. When, due to operational reasons, the lift is stopped at relatively low elevations (lower than 1.75m above the ground) personnel must be careful to avoid impact with parts of the machine not marked with special labels. (**Picture 12**)

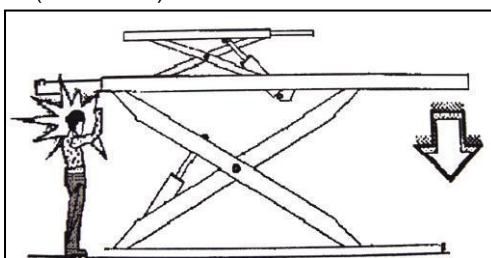

**Picture 12**



**Risk of falling (vehicle)**

This hazard may arise in the case of incorrect positioning of the vehicle on the platforms, overweight of the vehicle, or in the case of vehicles of dimensions that are not compatible with the capacity of the lift.

When the platform is being tested, the vehicle engine can not be turned on.

There is nothing should be placed on the lift-lowering area and the movable parts of the lift.

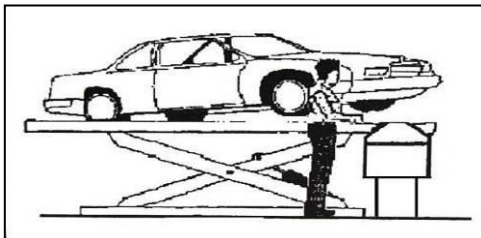

Picture 13



**Risk of slipping**

The floor caused by lubricant contamination of around the lift. The area beneath and immediately surrounding the lift and also the platforms must be kept clean. Remove any oil spills immediately.(Picture 14)

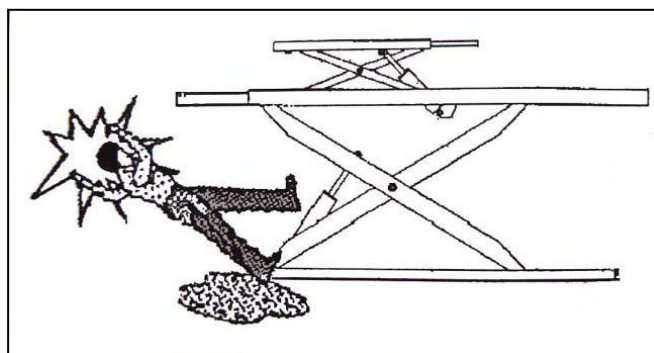

Picture 14



**Risk of electric shock**

Risk of electric shock in areas of insulated and shattered electric equipments

Do not use jets of water, steam solvents or paint next to the lift, and take special care to keep such substances clear of the electrical control panel.



**Risks related to appropriate lighting**

The operator and the maintenance fitter must be able to assure that all the areas of the lift are properly and uniformly illuminate compliance with the laws in force in the place of installation.

During up and down operations, the operator should continually observe the lift and can operate it only in the position of operator. When lifting and lowering the vehicle, the cushion needs being put in the bottom of chassis.



**The handling of safety devices is strictly forbidden. Never exceed the maximum carrying capacity of the lift, make sure the vehicles to be lifted have no load.**

**It is therefore essential to adhere scrupulously to all regulations regarding use, maintenance and safety contained in this manual.**

## 6. Installation



Skilled and authorized personnel only should be allowed to perform these operations, follow all instructions shown below carefully, in order to prevent possible damage to the car lift or risk of injury to people.

### Installation requirements (Picture 15)

- The car lift must be installed according to the specified safety distances from walls, pole -The specified safety distances from walls must be 600 mm at least, taking into consideration the necessary space to work easily. Because space for the control site and for possible runways in case of emergency is also necessary.
- The room must be previously arranged for the power supply and pneumatic feed of the car lift.
- The room must be 4000 mm in height, at least.
- The car lift can be placed on any floor, as long as it is perfectly level and sufficiently resistant. (Concrete grade above C20.the thickness of concrete $\geq$ 150mm)
- All parts of the machine must be uniformly lit with sufficient light to make sure that the adjustment and maintenance operations can be performed safely, and without reflected light, glare that could give rise to eye fatigue.
- The integrity of arrived goods should be checked before the lift is installed.
- Moving and installing lift should follow the process as the picture instructs.



The transport and storage of machine refers to "TRANSPORT AND STORAGE" on page

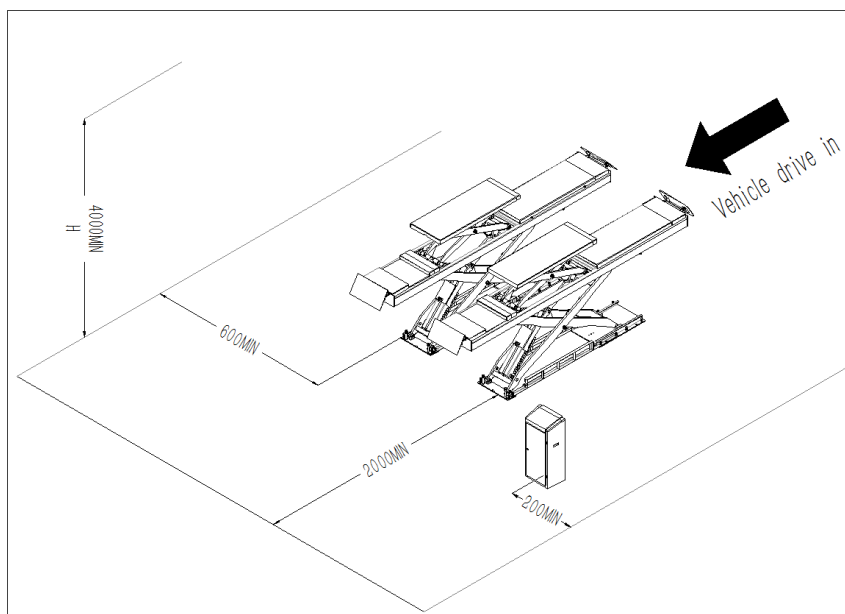

Picture 15



**Note:** The foundation of the end of the lift platform P1, P2 is the structure of concrete. When the thickness of inside level ground is less than 150mm, the end of P1, P2 should be irrigated the acreage: 6000 $\times$ 2500mm and thickness of concrete $\geq$ 150mm

The basic thickness of concrete and leveling are keys, shouldn't egregiously expect the ability of level adjustment of machine-self.

Installation scheme for scissor lift

Equipment basic picture

Picture 16 (The control box can be placed on the left or right)

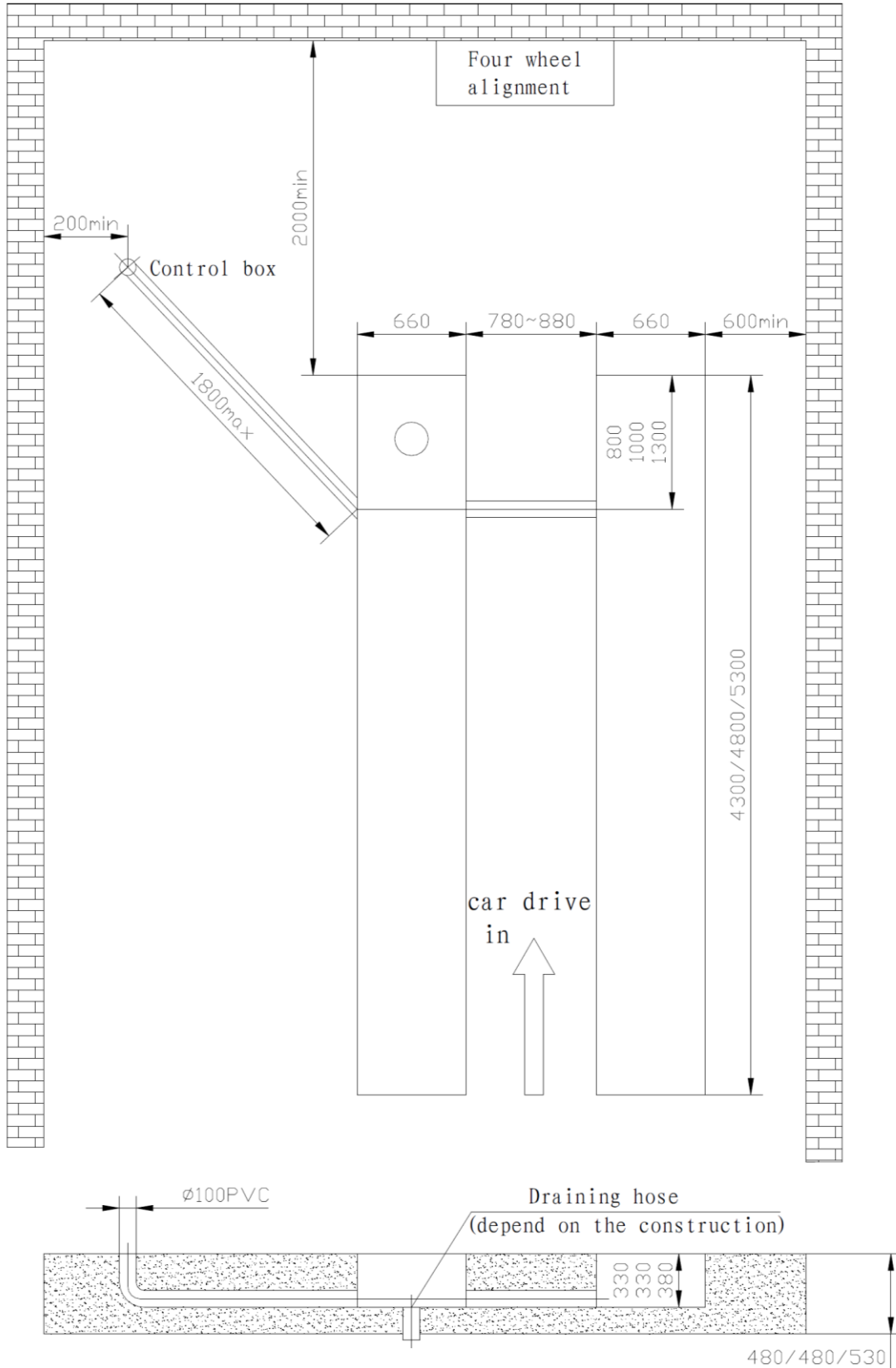

**Platform Installation:**

- Place two lift platforms on the position of the location
- The label on the machine should face outward
- The bottom of oil cylinder is located in the frontage of machine (the direction of getting on the vehicle)
- Use fork car or other lifting equipments to lift the platform (**Picture17**) and make sure that the safety equipment of machine is both turned on and locked.

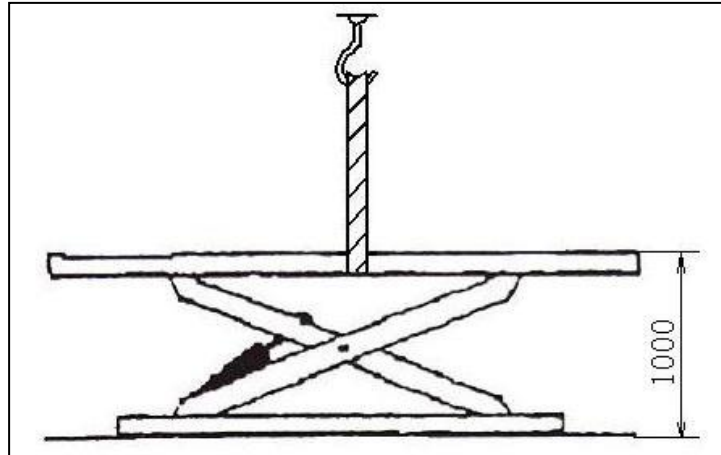

**Picture 17**



**To avoid failure of machine safety equipment, can insert a wood in the middle part of joint-pole. Prohibit working beneath the lift when hydraulic system is not completely equipped with hydraulic oil and take the action of up and down operations.**

**-When moving the lift platform, adjust the space between two platforms; make sure that the two platforms are parallel.**

**Ground bolts installation**

The ground bolts installation must start after the expiry date on the maintenance of concert, otherwise, it will affect the quality of solidity.

- Adjust the parallel of the platform and the distance of two platform as **Picture 18** requires.
- Fix the anchor bolts with a percussion electric drill (percussion drill bit is of 16), drill to 120mm hole and clean the hole.(**Picture 18**)
- Use light hammer to install the ground bolts into the hole (need not install the central expanded nail of ground bolts, install it after level adjustment.) (**Picture 19**)

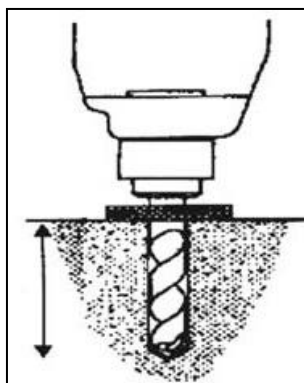

**Picture 18**

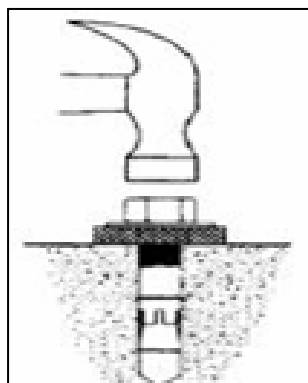

**Picture 19**

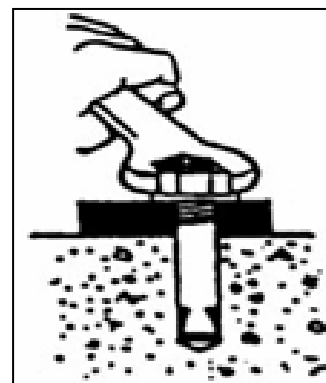

**Picture 20**

**Level adjustment**

- By using a level bar and the horizontal pipe and adjusting the adjustment screws at two sides of the base plate.
- If platform unevenness is resulted from basic unevenness, use iron block to fill up the low place.(**Picture 21**)
- After level adjustment, insert the central expanded nail of ground bolts and use heavy hammer to hammer it.(**Picture 19**)
- Screw down the ground bolts cap(**Picture 20**)

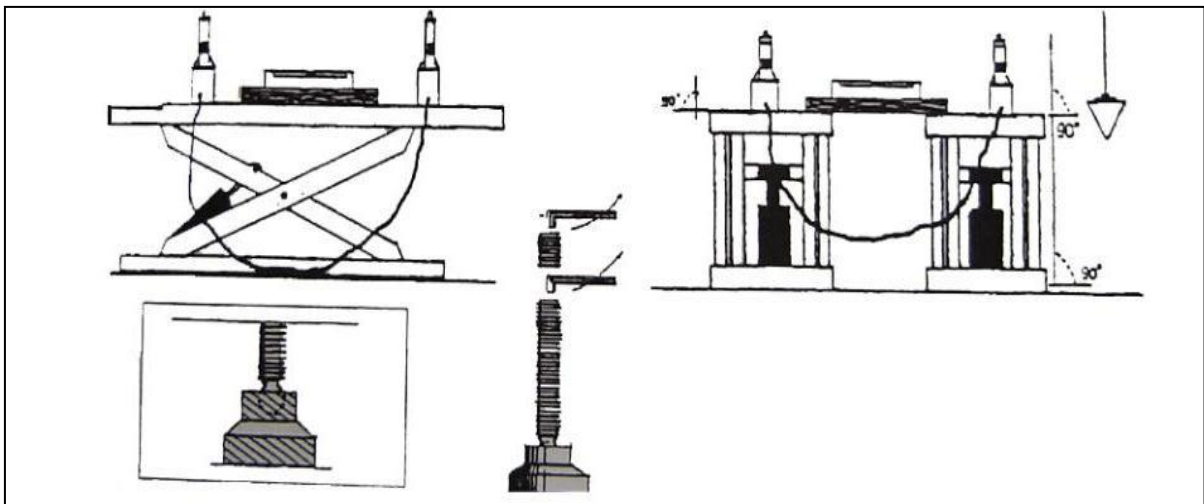

**Picture 21**

**Line connection**

Connect the electrical and oil line according to << circuit diagram>> and <<oil hose connection diagram>>.



Only after connecting the hydraulic system can connect the air loop, can not damage oil pipe, wire, and air pipe.

In the process of connecting oil pipe and air pipe, pay particularly attention to the protection of pipe tie-in to prevent abnormal thing from entering oil loop and air loop, then damaging hydraulic system.

**Electric circuit connection**

Follow the stated line-diameter and line-number of <<the circuit diagram>> to connect electric circuit.

1	3	4	5
PE	L1	L2	L3

**Picture 22**

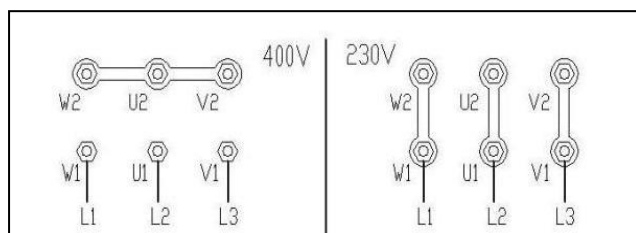

**Picture 23**





**Only skilled special person is allowed to perform the operations.**

- open the control box' front cover
- connection of power supply: the 400VAC three-phase and four-line connection wires (4x1.5mm<sup>2</sup> cable wire) for power supply are connected to L1,L2,L3, and PE labeled entering-wire terminal in control box. The PE ground wire is connected under the bolt marked ground firstly (**Picture 22**) and then connected under the bolt marked ground of two platforms.
- if the lift is operated at 230V three-phase, change the connection on the transformer and motor. (**Picture 23**)
- connect the limit switch to the corresponding terminal in the control box.

**Hydraulic pipeline connection**

Follow <<oil hose connection diagram >> to connect the hydraulic oil hoses



**Only skilled and authorized person is allowed to perform the operations. And pay particularly attention to the protection of vita head.**

- Following tubing number to lead the high-pressure tubing out from the "working stop valve G" and "H" of control box and then connect it to oil cylinder. (Refer to <<oil hose connection diagram>>)
- When connecting tubing, pay attention to the protection of tubing tie-in to prevent impurities from entering hydraulic circuit.



**When connecting the tubing, be care of the mistake of each tubing number.**

**During the standard installation, control box is in the nearside of vehicle-entering direction. If placed on the right should adjust relevant tubing.**

**Compressed air pipe connection**

Follow <<air loop diagram>> to connect air loop



**Only skilled and authorized person is allowed to perform the operations.**

- Connect Φ8×6 compressed air supply pipe to the air supply jaws of pneumatic electromagnetic valve inside the control box. (**Picture24**)
- Follow <<air loop diagram >> to lead the compressed air pipe out from pneumatic electromagnetic valve and then connect it to the uplifted-pawl air valve. (**Picture 25**)
- Pay attention to the protection of windpipe tie-in to prevent impurities from entering compressed air circuit.
- Connect compressed air pipe to the extra-installed grease separator which is in front of control box to prolong the life of pneumatic components and the reliability of action.



**Picture 24**



**Picture 25**



In the process of windpipe installation, the windpipe cannot be folded or tied to avoid that the air loop is not smooth or it is jammed.

Before leading the compressed air supply pipe to the air supply jaws of pneumatic electromagnetic valve inside the control box, should extra install grease separator to separate compressed air, avoiding the failure of pneumatic cell action.

## 7. Adjustment

### Preparation



Add oil and check the order of phase.

After installing lift as Picture 16 required and connecting hydraulic circuit, electric circuit and air loop, operate it as following:

-open the hydraulic oil tank, add 18L corresponds to wearable hydraulic oil into the oil tank, the hydraulic oil is provided by the user.



Make sure the clean of hydraulic oil, prevent any impurity into the oil line, lead the digest of the oil line and no working of the solenoid valve.

-Press the "POWER" button to turn on power, clicking the "UP" button, check whether the motor turns clockwise (looking downward), if not press "POWER" button, change the phase of the motor.

When turn on power, the high voltage will exist in the control box, only authorized person can operate it.

### "PHOTO" button operate instruction(optional part)



- "PHOTO" button shall be used in the first installation, and used to adjust the level degrees of two platforms. In two of the situations there is no lifting, descent, locking function.

- "PHOTO" button shall be pressed before user presses other button when the platform is at the lowest position

- Press "PHOTO" button during adjustment then follow the adjustment section 5 to operate.

- It is forbidden to use "PHOTO" button during normal operation, this button is only for adjustment.

### Main machine oil make-up adjustment



**Do not open both valves at the same time, platform movement will be unpredictable.**

**In Leveling position, only one side of the lift will move.**

**Use extreme care if a vehicle is on the lift**

- Turn the selector switch on the control panel to the "MAIN" position.

- Close the oil make up stop valve "G" on the main machine and the oil make up stop valve "H" on the sub machine.

- Press "UP" button SB1, and thus the left platform (looking from machine head direction) is lifted to about 1000mm.

- Press the "DOWN" button SB2 to lower the left platform to the lowest position.

- Then lift it up to approximately 1400mm.

- Turn the adjustment switch SA2 (fix on the side of electrical board) to "ADJUST" position.

- Open the oil make up stop valve "G" on the main machine.

- Press "UP" button SB1, and the right platform (looking from machine head direction) is lifted to about 1000 mm.
- Press "DOWN" button SB2 to lower the platform to the lowest position.
- Repeat the lifting and lowering process for 8-9 times to vent air automatically.
- Then lift the right platform to 1400mm. (two platforms of the main machine are lifted to the same height).
- Close the stop valve for oil make-up "G", turn SA2 to "WORK" position, and so come into the normal lift mode.
- Check oil leakage of the oil line and air tightness of the air loop.
- Turn right opening the "PHOTO" button to let the photocell working to protect the lift only to be operated at the same level.

### Sub machine oil make-up adjustment



**Do not open both valves at the same time, platform movement will be unpredictable.**

**In Leveling position, only one side of the lift will move.**

**Use extreme care if a vehicle is on the lift**

- Turn the selector switch SA1 on the control panel to the "SUB" position.
- Close the oil make up stop valve "G" on the main machine and the oil make up stop valve "H" on the sub machine.
- Press "UP" button SB1, and thus the right platform of the sub machine (looking from machine head direction) is lifted to about 300 mm.
- Press the "DOWN" button SB2 to lower the right platform of sub machine to the lowest position.
- Then lift the right platform of the sub machine up to approximately 400mm.
- Turn the adjustment switch SA2 (fix on the side of electrical board) to "ADJUST" position.
- Open the oil make up stop valve "H" on the sub machine.
- Press "UP" button SB1, and the left platform (looking from machine head direction) is lifted to about 300 mm.
- Press "DOWN" button. "SB2" to lower the left platform of the sub machine to the lowest position.
- Repeat the lifting and lowering process for 8-9 times to vent air automatically.
- Then lift the left platform of sub machine to 400mm. (two platforms of the Sub machine are lifted to the same height).
- Close the stop valve for make-up oil "H", turn SA2 to "WORK" position, and so come into the normal lift mode.
- Turn right opening the "PHOTO" button to let the photocell working to protect the lift only to be operated at the same level.

**Check:** whether the locations of two safety-pawl equipment are agile and reliable, no leakage of the hydraulic system and the air system.



**When conducting oil make-up operation, the platforms must not be load.**

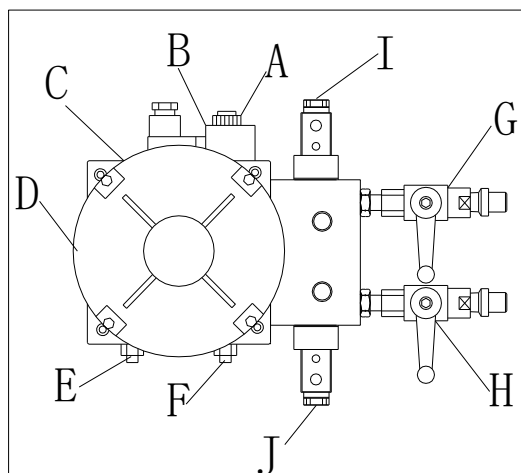

Picture 26

#### No load of main machine test

- Turn on the power switch QS.SA1 is on the “main machine” position and SA2 is on the “working” position. Close the main machine adjusting level valve G and sub machine adjusting level valve H.
- Press “UP” button SB1, pay attention to the synchronization and placidity of the lifting.
- Check whether highest limit of platforms is correct and reliable. Adjust the position of limit switch to control the maximum lifting height of platform shall not exceed 1850mm.
- Press “LOCK” button SB3,check whether safety pawl is correctly located, the oil line and the air line are leakage.

#### No load of sub machine test

- SA1 is on the “sub machine” position. Press “UP” button SB1, pay attention to the synchronization and placidity of the lifting.
- Check whether highest limit of platforms is correct and reliable.
- Press “LOCK” button SB3,check whether safety pawl is correctly located, the oil line and the air line are leakage



**When testing the lift, no person or other things are allowed to stand or be put near the two sides and beneath the machine. If any abnormal is found, stop it timely. After clearing obstacles, do the test again.**

#### Load of main machine test

- SA1 is on the “main machine” position
- Drive the vehicle whose weight doesn't exceed maximum lift weight to the platform, and then the driver leave it.
- Press “UP” button SB1, lift the platform and pay attention to the synchronization and placidity of the lifting.
- Check whether rack and hydraulic pump work normally .
- Check whether highest limit of platforms is correct and reliable.
- Press “LOCK” button SB3,check whether safety pawl is correctly located, the oil line and the air line are leakage.

### Load of sub machine test

- SA1 is on the "sub machine" position .Put the lift rubber cushion on the strut-seat
- Press "UP" button SB1, lift the platform and pay attention to the synchronization and placidity of the lifting.
- Check whether rack and hydraulic pump work normally
- Check whether highest limit of platforms is correct and reliable.
- Press "LOCK" button SB3,check whether safety pawl is correctly located ,the oil line and the air line are leakage.



**When beginning load of machine test, no person or other things are allowed to stand or be put near the two sides and beneath the machine.**

**Test vehicle whose weight doesn't exceed maximum lift weight.**

**Check whether the oil line and the air line are leakage. If any abnormal is found, stop it timely.**

**After clearing obstacles, do the test again.**

## 8. Operation



**Only skilled and having been trained personnel is allowed to perform the operations. Check proceedings as following.**

### **Text before operation:**

- Clear obstacles around the lift before operation.
- Pay attention to the synchronization and placidity of the lifting.
- Check whether the safety claw is flexible and reliable.
- Check whether the lift will stop automatically when it lift to the highest position
- No air leakage in the solenoid valve, air cylinder, air hose and union.
- Check whether the working sound of motor and gear pump are normal.
- Check whether the lifting vehicle or other goods exceed the capacity of the lift.

### **Operation notices**

- Speed of vehicle should be kept in 5km/h when vehicle drives on the lift.
- The front wheel lies on the middle of the groove of turntable(the position of groove is adjustable) and the rear wheel lies on the sliding plate when vehicle stop.
- Tighten the brake and stack up antiskid(equipped by user) for vehicles.
- Press up button to lift the vehicle for 200-300mm,pay attention to the synchronization of the lifting.
- Go on press up button to lift the vehicle to the needed height.
- The chassis of vehicle should be filled up with rubber mat when the sub machine is lifting and lowering. The telescopic boom of sub machine should be taken back when the lift lowers.
- Pay attention to the synchronization of the lifting and lowering. If any abnormal is found, stop the machine timely, check and remove the trouble.
- The lift should be locked to keep the two insurance claw of platform in the same horizontal height during maintenance and four wheel alignment adjustment. Only after locking operation, personnel can enter below the lift and vehicle.
- Check whether the insurance claw is out of the insurance gear entirely and personnel is around the vehicle and the platform.
- Press down button to lower the vehicle to the ground or needed height.

-When the equipment is not used for a long time or over night, the machine should be lowered to the lowest position on ground, and remove vehicle, and cut off power supply.

**Instructions on control panel operation**

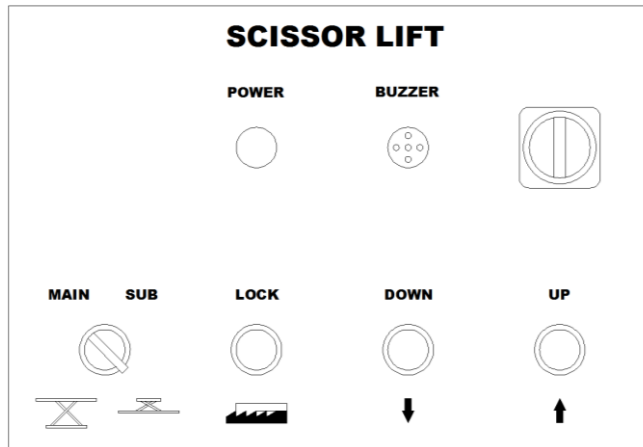

Picture 27

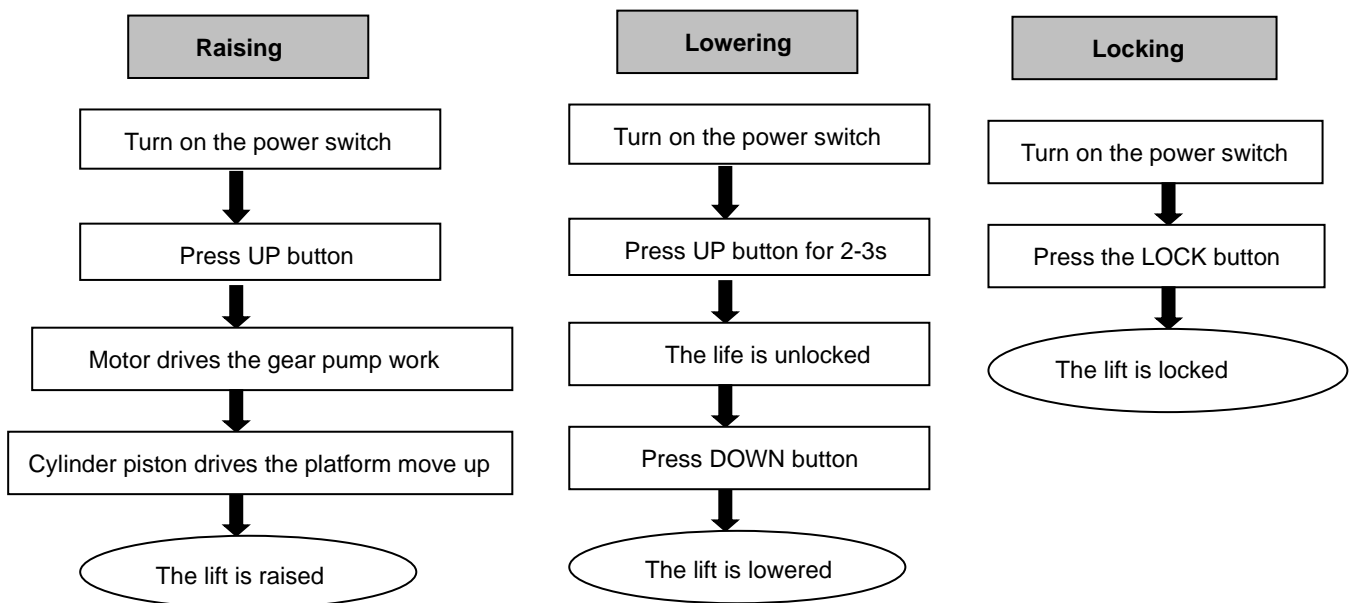

**Emergency manual operation for lowering (power failure)**



When lowering through manual operation, should observe the condition of platform at any time because there is vehicle on the platform. If there is anything abnormal, screw down oil loop valve immediately.(refer to **Picture 28**)

**The process of manual operation**

- Firstly lift two safety pawls of platform and use thin iron bar to fill up it.
- Switch off the power button (avoid abruptly incoming electricity). Open the back cover of control box to find the electromagnetic valve A for lowering.
- Loosen manual oil loop stud at the end of lowering electromagnetic valve core, then the platform begins lowering.(**Picture 28**)

-After the machine has been lowered, screw down manual oil loop stud timely, the process of manual lowering comes to the end.

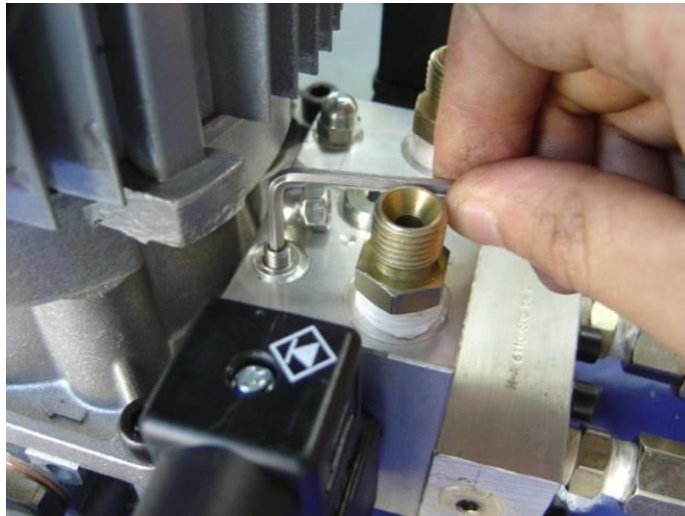

Picture 28

## 9. Maintenance and care



**Skilled personnel only is allowed to perform the operations**

### Daily checking items

The user must perform daily check. Daily check of safety system is very important – the discovery of device failure before action could save your time and prevent you from great loss, injury or casualty.

- Always wipe clean ,keep the machine clean.
- Clear barriers and ground oil, keep the working condition clean.
- Check the integrity of each safety devices, ensure the motion is flexible and reliable.
- Check the reliability of limit switch motion.
- Check whether oil/air leakage of the machine exist.

### Weekly checking items

- All bearings and hinges on this machine must be lubricated once a week by using an oiler
- Check the working conditions of safety parts.
- Check the amount of oil left in the oil tank. Oil is enough if the carriage can be raised to highest position. Otherwise, oil is insufficient.
- Check whether the expansion bolts well anchored.

### Monthly checking items

- The safety gear, the upper and lower sliding blocks and other movable parts must be lubricated once a month.
- Check whether the foundation bolts well anchored.
- Check the abrasion and leakage of oil/air hose.

### Yearly checking items

- The hydraulic oil must be replaced once a year. The oil level should always be kept at upper limit position.
- Check abrasion and damage of all the active parts.
- Check the lubrication of sliders. Lubricate it if drag phenomenon exist.



The machine should be lower to the lowest position when replace hydraulic oil, then let the old oil out, and should be filtering the hydraulic oil.

-Each team checks the agility and reliability of pneumatic safety equipment.

### **Storage after use**

When the machine does not use for a long time:

- Cut off the power supply and air source.
- Lubricate all the active parts.
- Drain the hydraulic oil of oil cylinder, oil hose and oil tank.
- Sheathe the machine with dust-proof cover.



## 10. Trouble shooting table



Skilled personnel only is allowed to perform the operations

Failure Phenomena	Cause and Phenomena	Resolutions
The motor does not run in lifting operation.	①Connection of power supply wires is not correct.	Check and correct wire connection
	②The AC contactor in the circuit of the motor does not pick up.	If the motor operates when forcing the contactor down with an isolation rod, check the control circuit. If the voltage at two ends of the contactor coil is normal, replace the contactor.
	③The limit switch is not closed.	Check the limit switch, wires and adjust or replace the limit switch.
In lifting operation, the motor runs, but there is no lifting movement.	①The motor turns reverse.	Change the phases of the power supply wires.
	②It is normal while lifting with light load but abnormal while lifting with heavy load.	Lift is overloaded and is unable to carry the load being attempted. Carefully lower and remove vehicle from lift. The spool of the lowering solenoid valve is stuck by dirt. Clean the spool.
	③The amount of hydraulic oil is not enough.	Add hydraulic oil.
	④The "operation stop valve" is not closed.	Screw down the "Operation stop valve"
When press "DOWN" button, the machine is not lowered.	①The safety pawl are not released form the safety teeth.	First lift a little and then lowering
	②The safety pawl is not lifted.	The air pressure is not enough, the safety pawl is stuck or the air pipe is broken off, adjust pressure, check the air pipe and replace it.
	③The solenoid air valve does not work.	If the solenoid air valve is energized, but does not open the air loop, check or replace the solenoid air valve.
	④The lowering solenoid valve is energized but does not work.	Check the plug and coil of the lowering solenoid valve and check the right turn tightness of its end copper nut and so on.
	⑤The "antiknock valve" is blocked.	Remove the "antiknock valve" from the oil supply hole at the bottom of the oil cylinder, and clean the "antiknock valve".
The machine lowers extremely slowly under normal loads.	①The hydraulic oil has too high viscosity or frozen, deteriorated (in Winter).	Replace with hydraulic oil in accordance with the instruction book.
	②The "antiknock valve" for preventing oil pipe burst is blocked.	Remove or close air supply pipe and thus lock the safety pawl of the machine without lifting of the safety pawl. Remove the "antiknock valve" from the oil supply hole at the bottom of the oil cylinder, and clean the "antiknock valve".
The right and left platforms are not synchronous and not in the same height.	① The air in the oil cylinder is not vent completely.	Refer to " Oil Make-up 'Adjust' Operation".
	②Oil leakage on oil pipe or at its connections.	Tighten oil pipe connections or replace oil seals and then make-up oil and adjust levelness.
	③The "oil make-up stop valve" can not be closed tightly and almost make-up oil and adjust every day.	Replace oil make-up stop valve, and then make-up oil and adjust.
Noisy lifting and lowering.	①Lubrication is not enough.	Lubricate all hinges and motion parts (including piston rod) with machine oil
	② The base or the machine is twisted.	Adjust again the levelness of the machine, and fill or pad the base.

Table 3

## 11. Hydraulic pressure elements diagram

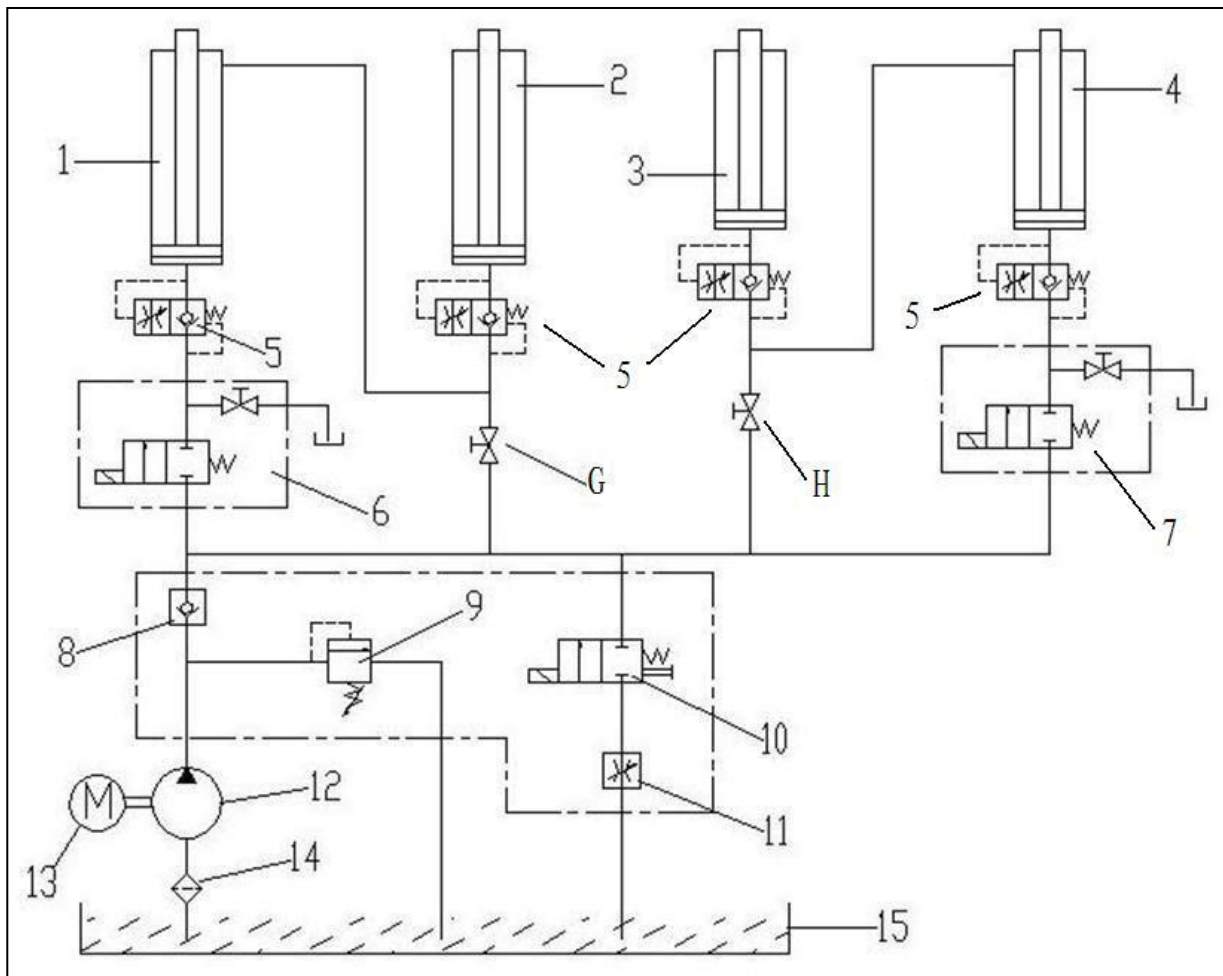

1. Main machine main cylinder
2. Main machine sub cylinder
3. Sub machine main cylinder
4. Sub machine sub cylinder
5. Stop valve
6. Main machine valve
7. Sub machine valve
8. One-way valve
9. Overflowing valve
10. Descent valve
11. Throttling valve
12. Gear pump
13. Pump motor
14. Filter
15. Oil tank
- G. Adjust level valve
- H. Adjust level valve

## 12. Oil hose connection diagram

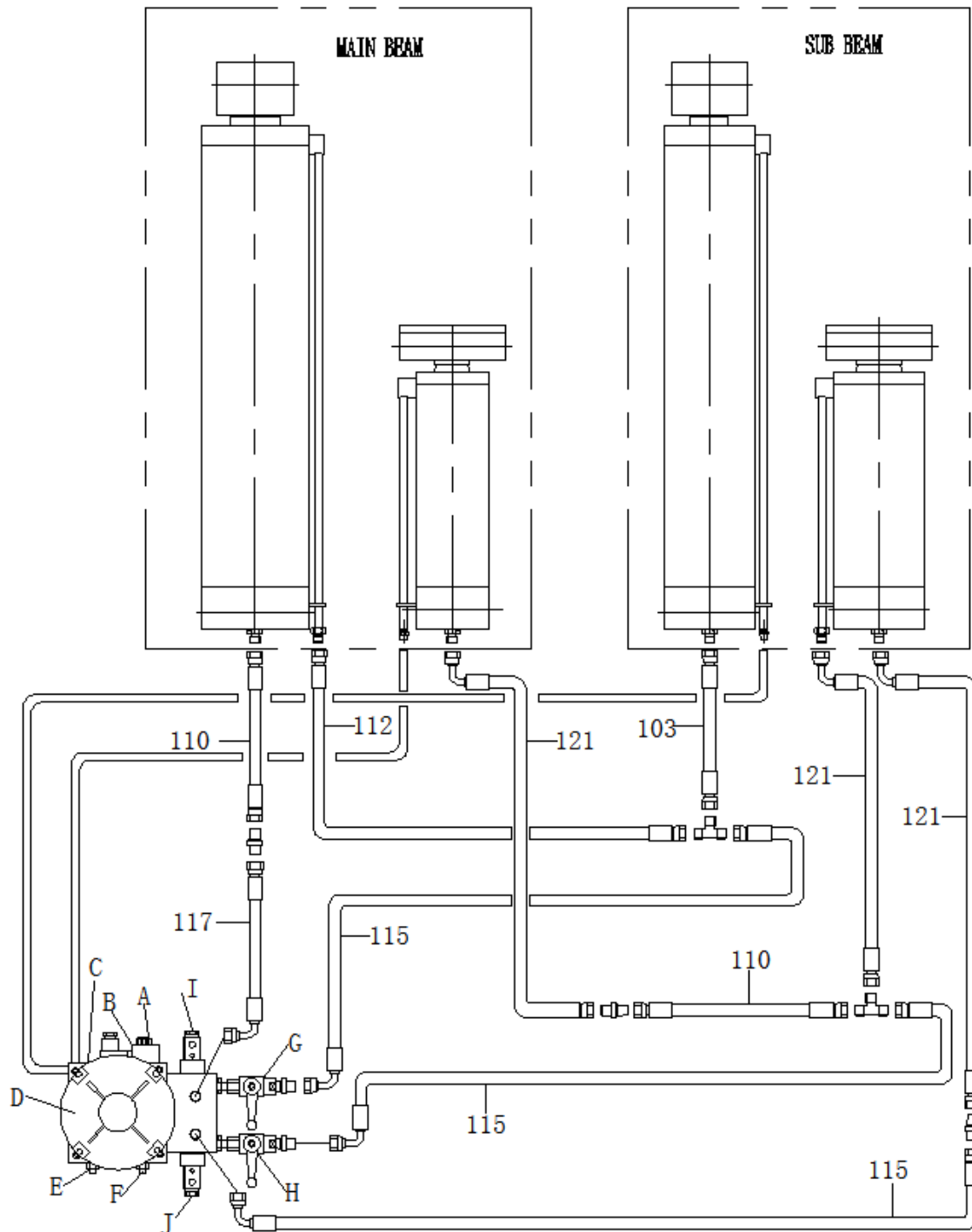

1. 103#~119# High pressure pipe
2. A: Descent valve core; B: Descent coil; C: One-way valve; D: Motor; E: Plug; F: Overflow valve; G: Main machine adjusting level valve; H: Sub machine adjusting level valve; I/J :Working valve

### 13. Circuit diagram

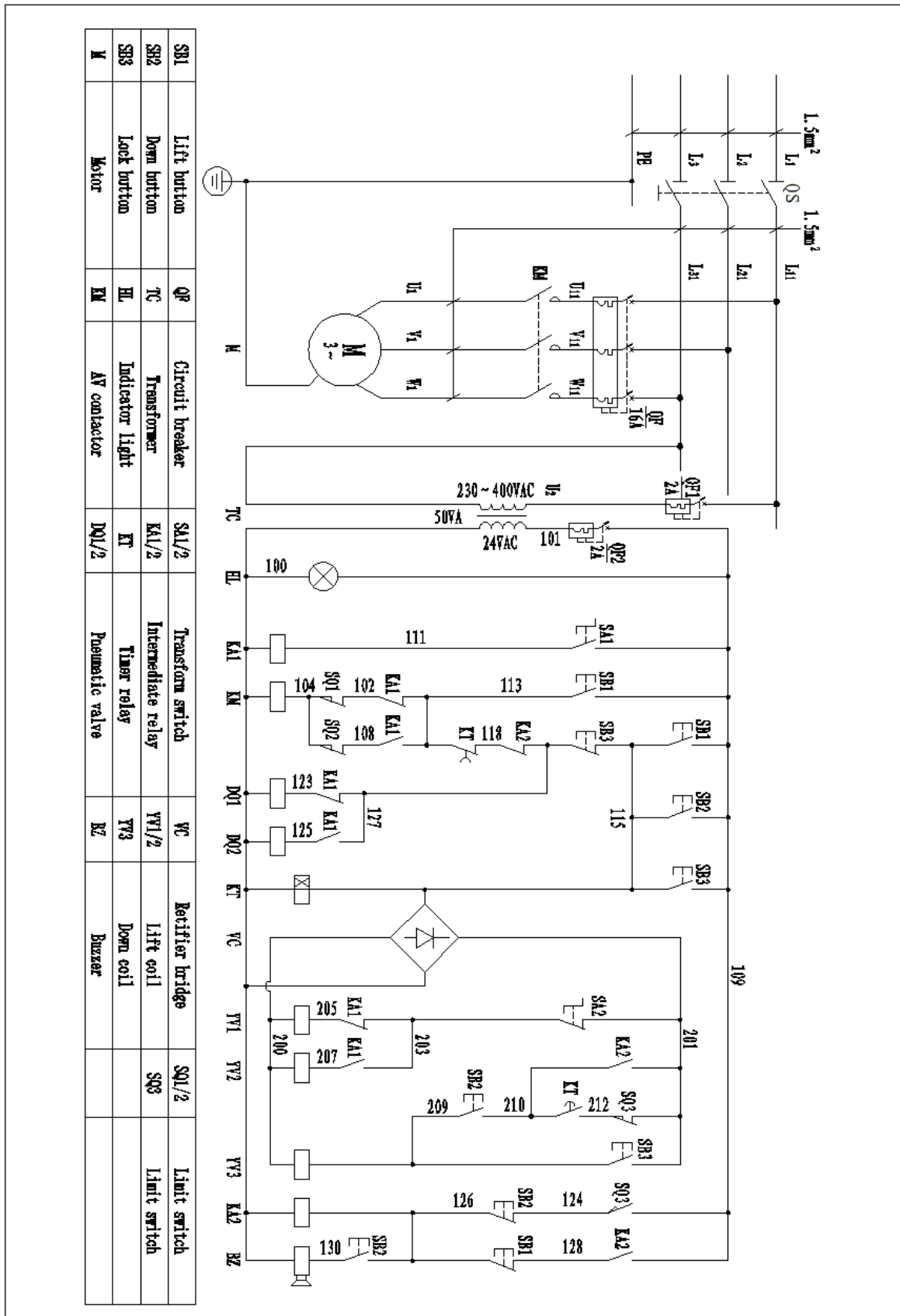

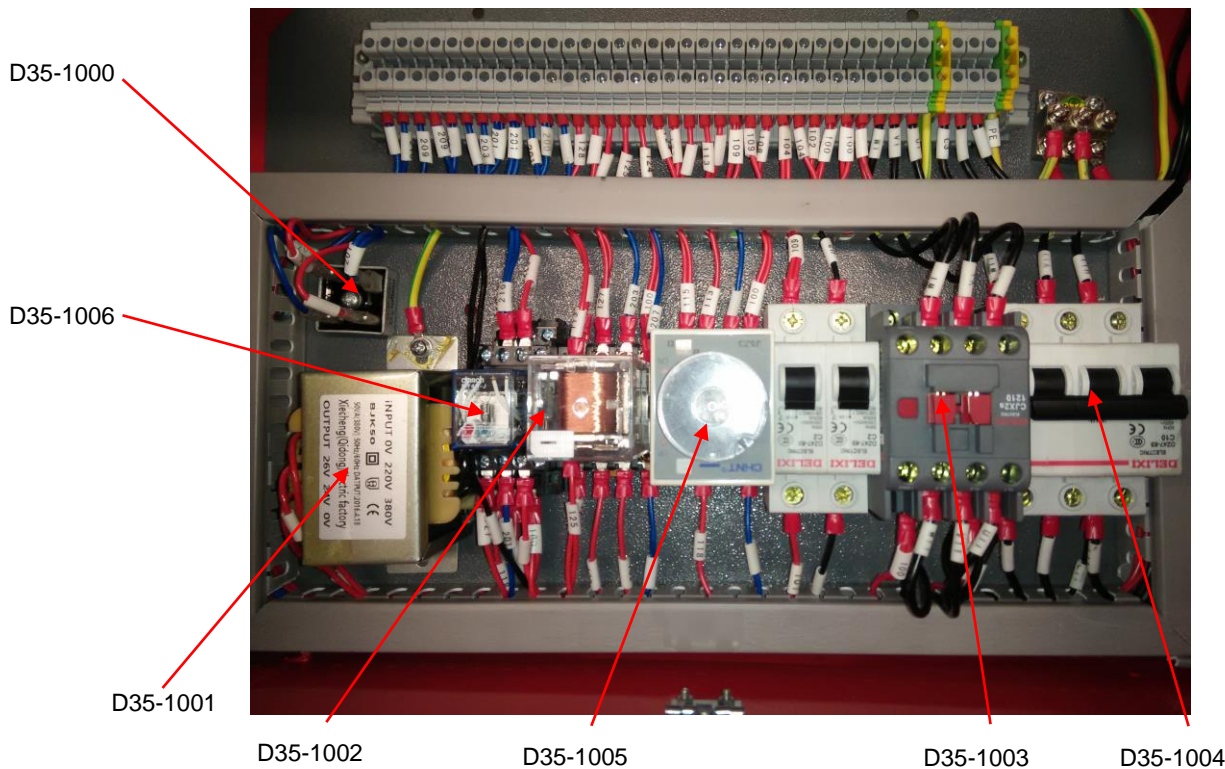
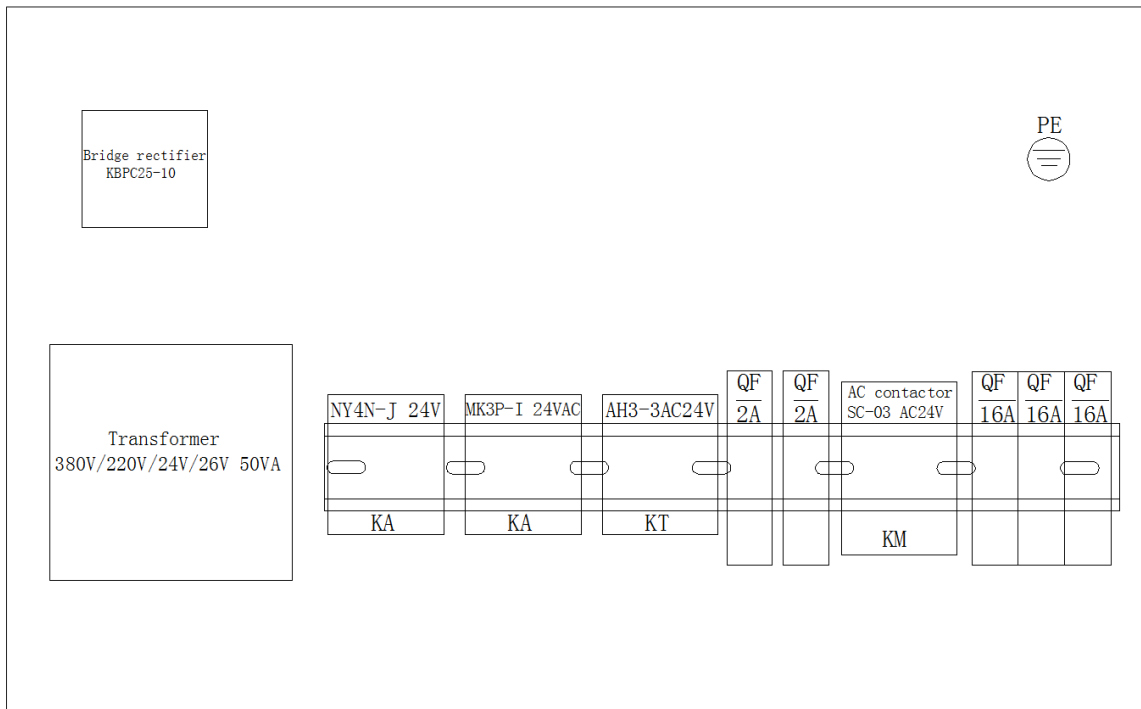

D35-1000	H-030-200013-5	bridge rectifier(D35,D45,D55)
D35-1001	D-038-000380-5	transformer(D35,D45,D55)
D35-1002		relay(D35,D45,D55)
D35-1003	H-030-050011-1	AC contactor(D35,D45,D55)
D35-1004		Circuit breaker(D35,D45,D55)
D35-1005	H-030-010020-1	Time relay(D35,D45,D55)
D35-1006		relay(D35,D45,D55)

### 14. Pneumatic drawing

#### Main platform

#### Sub platform

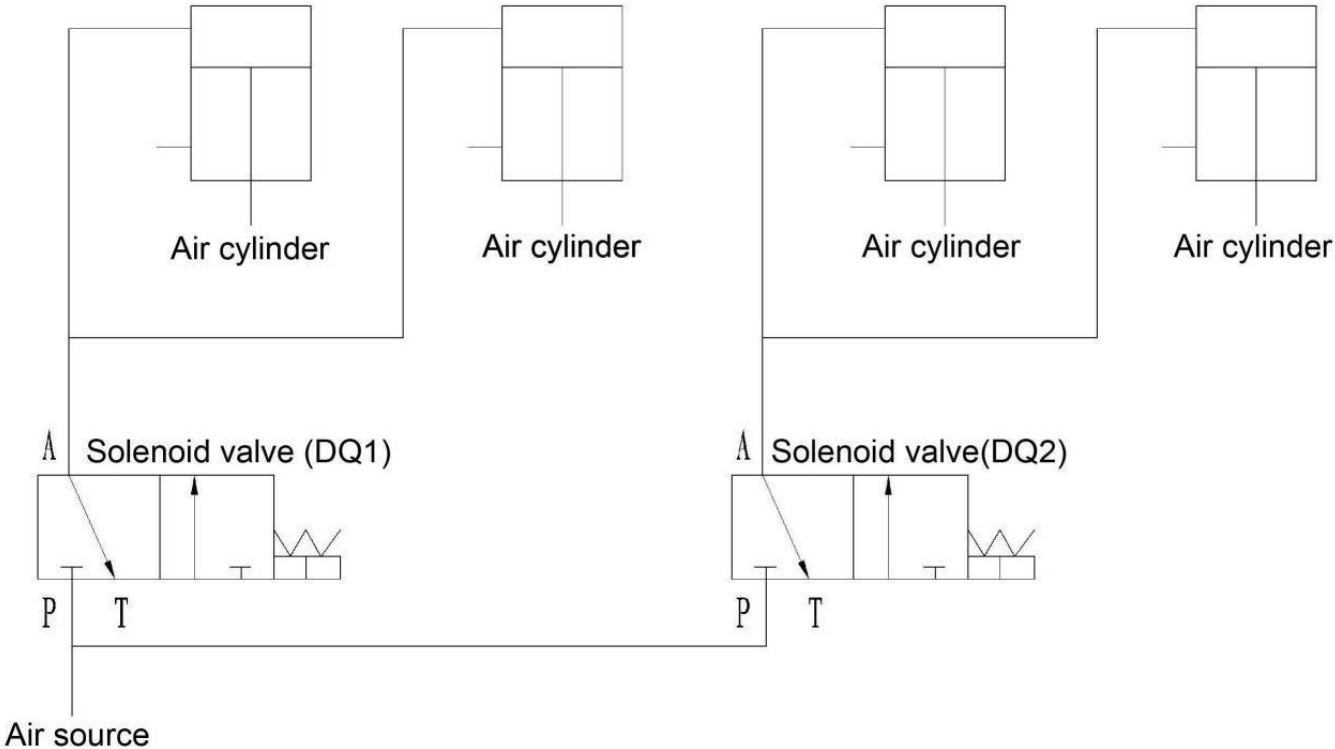

## 15.Expllosion drawing

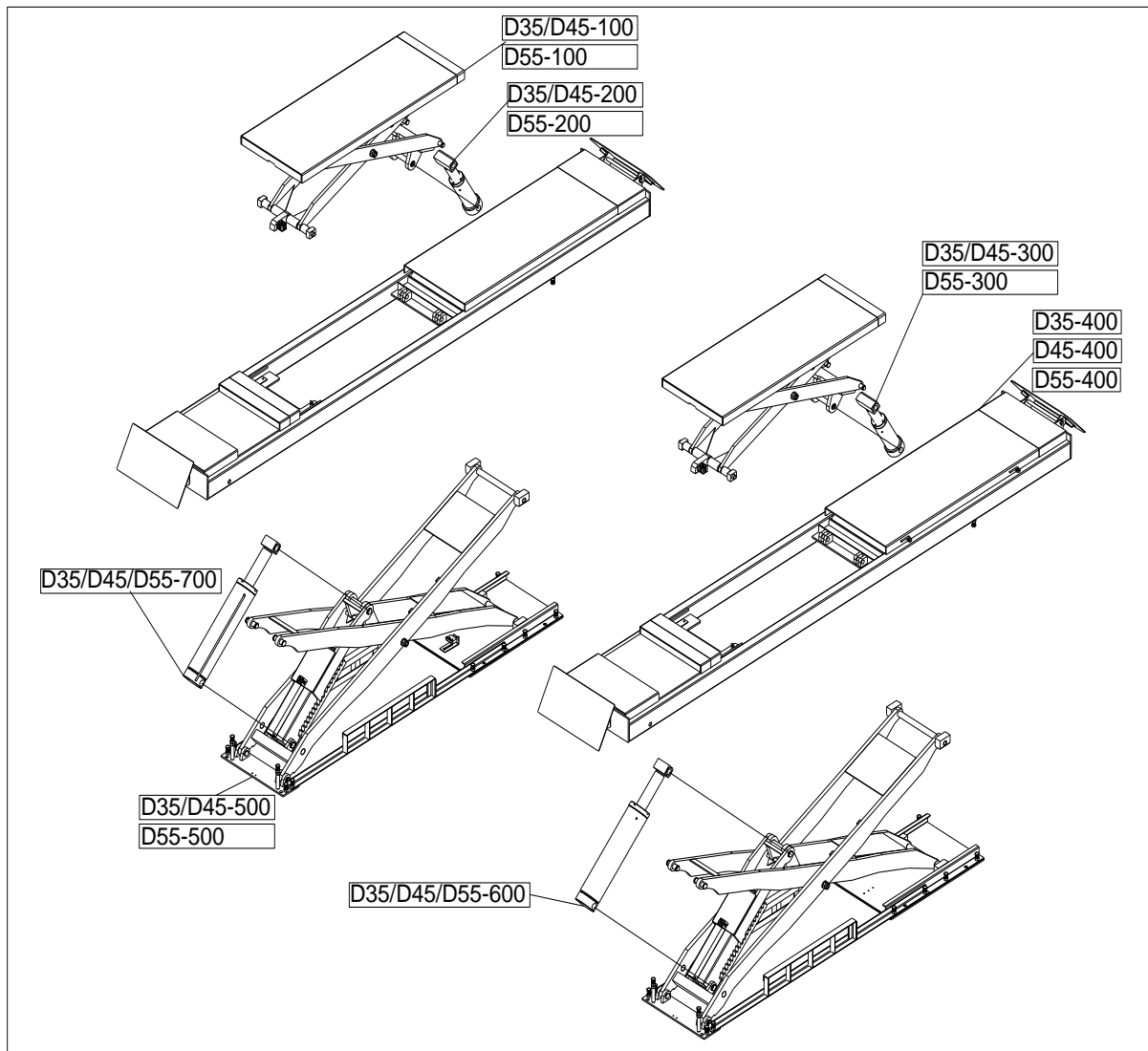

D35/D45-100	Complete sub machine assembly(D35,D45)
D55-100	Complete sub machine assembly(D55)
D35/D45-200	Complete sub oil cylinder assembly(sub machine,D35,D45)
D55-200	Complete sub oil cylinder assembly(sub machine,D55)
D35/D45-300	Complete main oil cylinder assembly(D35,D45)
D55-300	Complete main oil cylinder assembly(D55)
D35-400	Complete main platform assembly(D35)
D45-400	Complete main platform assembly(D45)
D55-400	Complete main platform assembly(D55)
D35/D45-500	Complete main machine assembly(D35,D45)
D55-500	Complete main machine assembly(D55)
D35/D45/D55-600	Complete sub oil cylinder assembly(main machine,D35,D45,D55)
D35/D45/D55-700	Complete main oil cylinder assembly(main machine,D35,D45,D55)

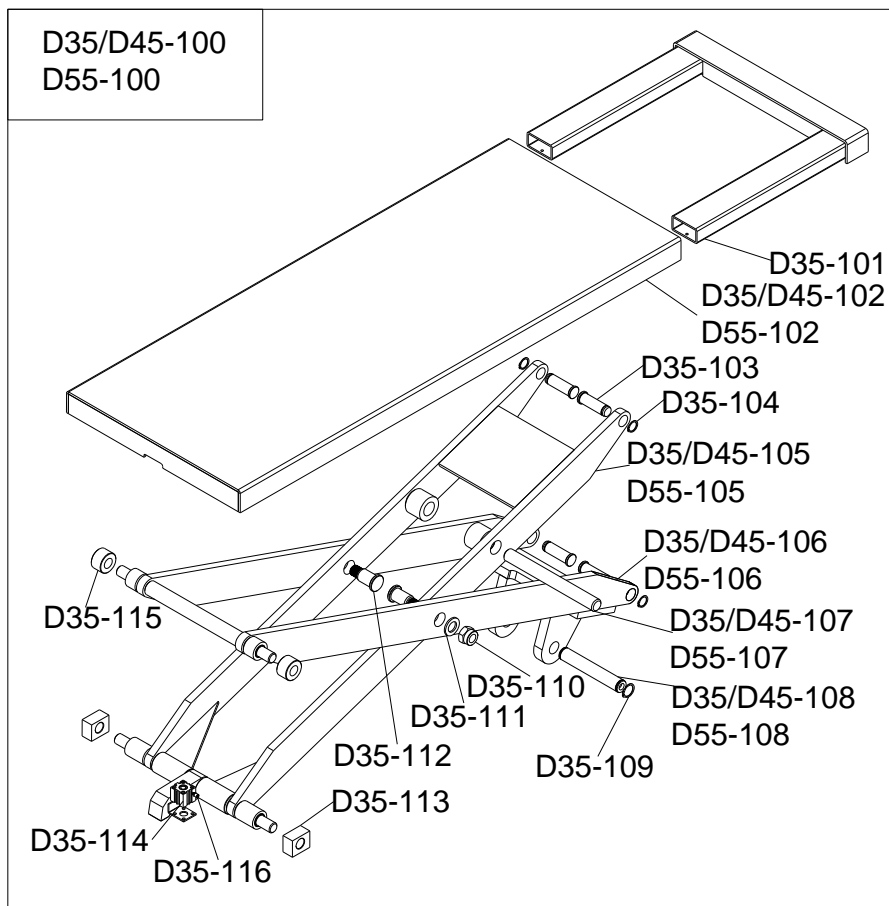

D35-101	Telescopic boom 552x538x60mm(D35,D45,D55)
D35/D45-102	top plate(D35,D45)
D55-102	top plate(D55)
D35-103	Stationary shaft(sub machine) (D35,D45,D55)
D35-104	shaft snap ring $\varnothing 25$ (D35,D45,D55)
D35/D45-105	Inner connecting rod(sub machine) (D35,D45)
D55/D45-105	Inner connecting rod(sub machine) (D55)
D35/D45-106	Outer connecting rod(sub machine) (D35,D45)
D55/D45-106	Outer connecting rod(sub machine) (D55)
D35/D45-107	upper stationary shaft of oil cylinder(sub machine) (D35,D45)
D55-107	upper stationary shaft of oil cylinder(sub machine) (D55)
D35/D45-108	downward stationary shaft of oil cylinder(sub machine) (D35,D45)
D55-108	downward stationary shaft of oil cylinder(sub machine) (D55)
D35-109	shaft snap ring $\varnothing 30$ (D35,D45,D55)
D35-110	hex locking nut M24(D35,D45,D55)
D35-111	flat washer $\varnothing 24$ (D35,D45,D55)
D35-112	centre shaft(sub machine) (D35,D45,D55)
D35-113	sliding block(sub machine) (D35,D45,D55)
D35-114	cylinder SSSA25X15(D35,D45,D55)
D35-115	Trundle sleeve(sub machine) (D35,D45,D55)



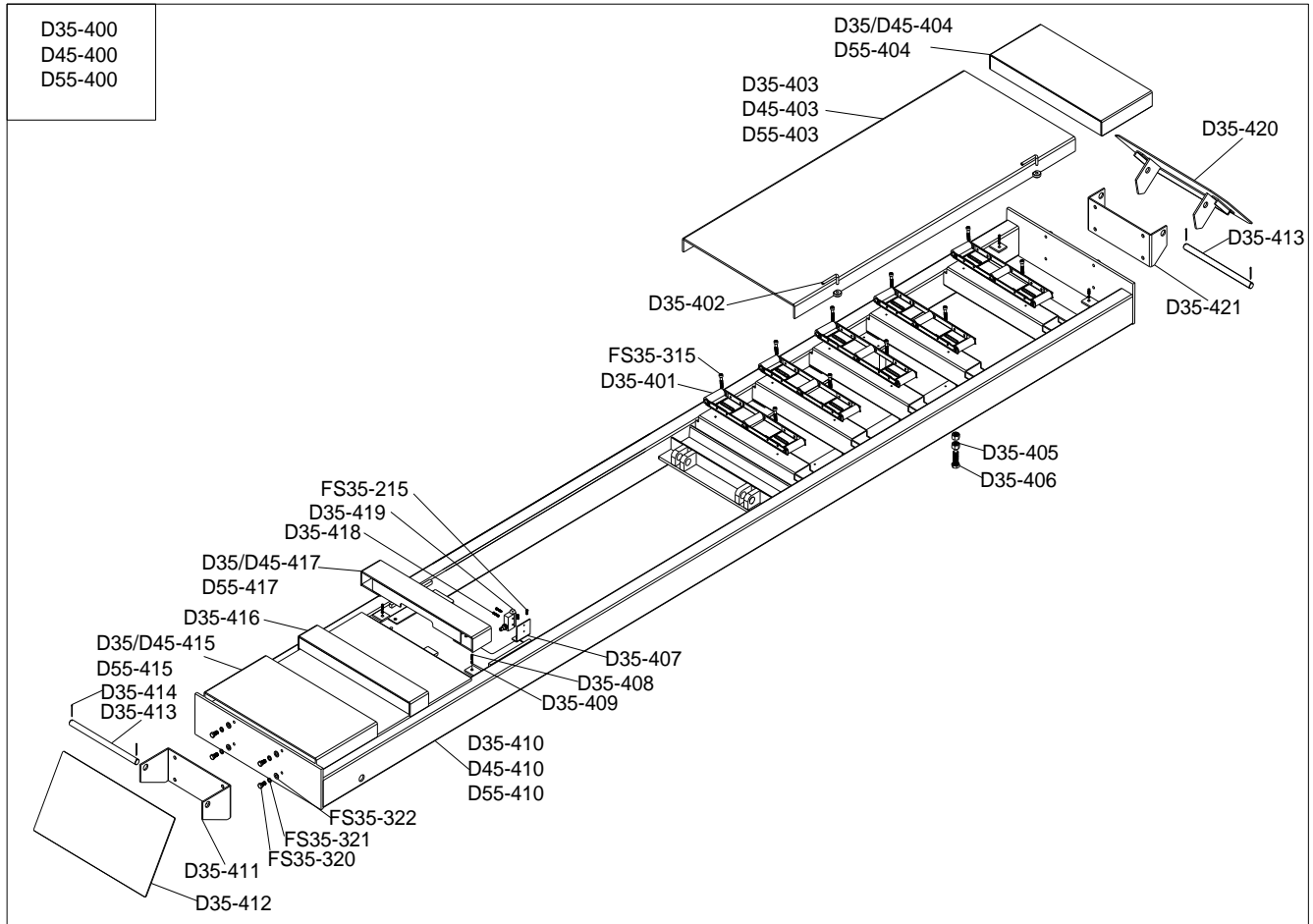

D35-401	side sliding plate roller(D35,D45,D55)
FS35-315	hex socket head cap screw M6X35(half teeth)(D35,D45,D55)
D35-402	side sliding plate fixed pin(D35,D45,D55)
D35-403	side sliding plate(D35)
D45-403	side sliding plate(D45)
D55-403	side sliding plate(D55)
D35/D45-404	Figure cover plate (D35,D45)
D55-404	Figure cover plate (D55)
D35-405	hex nut M16(D35,D45,D55)
D35-406	hex bolt M16X50(D35,D45,D55)
D35-407	limit switch support(D35,D45,D55)
D35-408	hex bolt M8X35(D35,D45,D55)
D35-409	hex nut M8(D35,D45,D55)
D35-410	main platform(D35)
D45-410	main platform(D45)
D55-410	main platform(D55)
FS35-322	flat washer $\varnothing 10$ (D35,D45,D55)
FS35-321	spring washer $\varnothing 10$ (D35,D45,D55)
FS35-320	hex bolt M10X20(D35,D45,D55)
D35-411	block car plate fixed support(D35,D45,D55)
D35-412	block car support(D35,D45,D55)
D35-413	shaft of block car support(D35,D45,D55)

D35-414	split pin(D35,D45,D55)
D35/D45-415	front padding block(D35,D45)
D55-415	front padding block(D55)
D35-416	mid padding block(D35,D45,D55)
D35/D45-417	rear padding block(D35,D45)
D55-417	rear padding block(D55)
D35-418	cross pan head screw M4X25(D35,D45,D55)
D35-419	limit switch LZ7311(D35,D45,D55)
D35-420	Loading dock board(D35,D45,D55)
D35-421	Fixed support of loading dock board(D35,D45,D55)
D35-422	Spring(D35,D45,D55)
FS35-215	hex screw M6X12(D35,D45,D55)

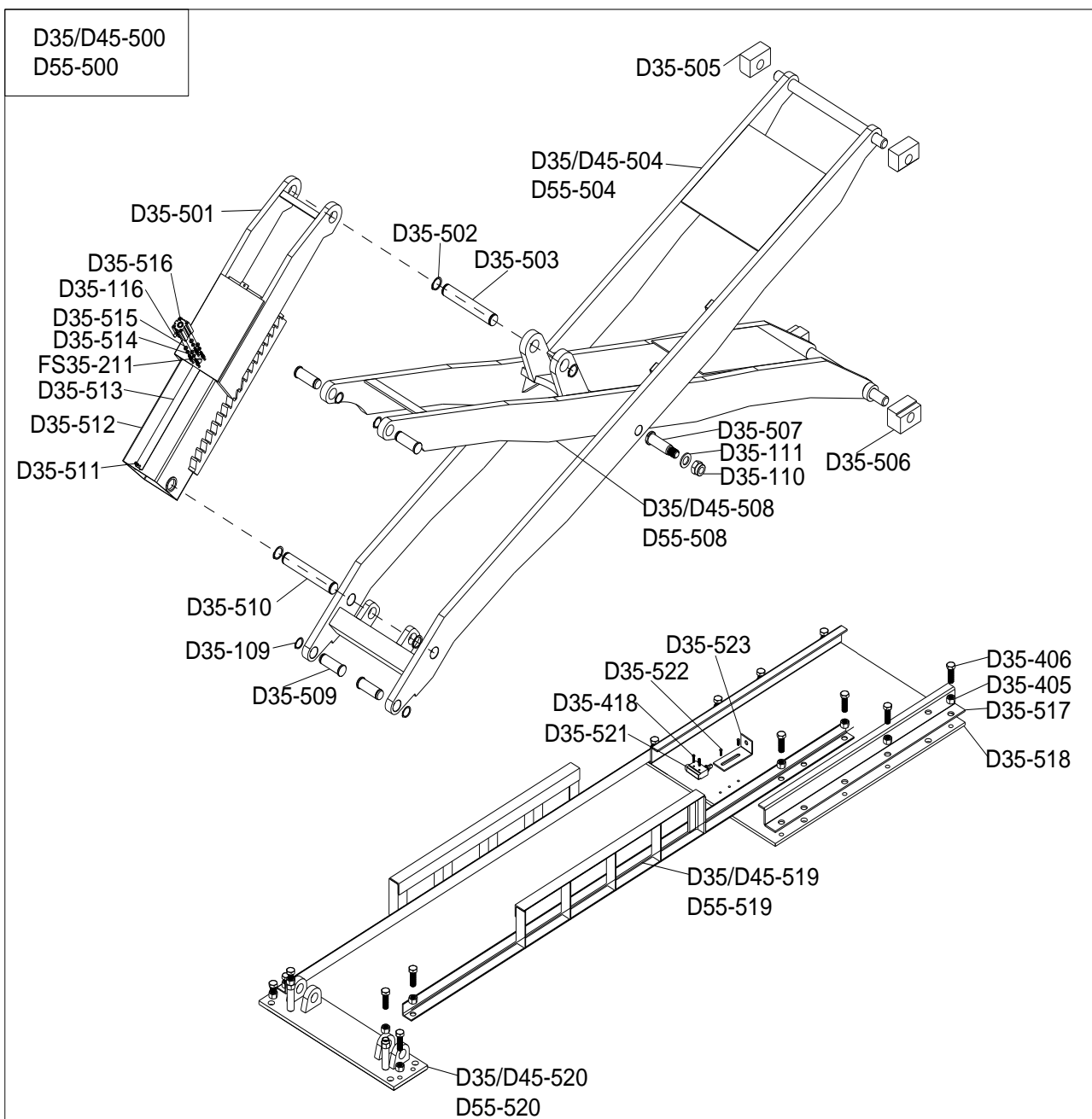

D35-501	Two teeth insurance holder (D35,D45,D55)
D35-502	shaft snap ring Ø35(D35,D45,D55)
D35-503	upper stationary shaft of oil cylinder(main machine) (D35,D45,D55)
D35/D45-504	Out connecting rod(main machine) (D35,D45)
D55-504	Out connecting rod(main machine) (D55)
D35-505	Upper sliding block(D35,D45,D55)
D35-506	Downward sliding block(D35,D45,D55)
D35-507	Centre shaft(main machine) (D35,D45,D55)
D35/D45-508	Inner connecting rod(main machine) (D35,D45)
D55-508	Inner connecting rod(main machine) (D55)
D35-509	Stationary shaft(main machine) (D35,D45,D55)
D35-510	downward stationary shaft of oil cylinder(main machine) (D35,D45,D55)
D35-511	hex socket head cap screw M5X10(D35,D45,D55)
D35-512	Insurance case(D35,D45,D55)
D35-513	cylinder wear strip(D35,D45,D55)
FS35-211	hex socket head cap screw M6X20(D35,D45,D55)
D35-514	spring washer Ø6(D35,D45,D55)
D35-515	flat washer Ø6(D35,D45,D55)
D35-516	cylinder SSSA25X25(D35,D45,D55)
D35-517	Guide folded plate(D35,D45,D55)
D35-518	big base plate(D35,D45,D55)
D35/D45-519	connecting iron assembly(D35,D45,D55)
D55-519	connecting iron assembly(D35,D45,D55)
D35/D45-520	small base plate(D35,D45,D55)
D55-520	small base plate(D35,D45,D55)
D35-521	limit switch LZ7312(D35,D45,D55)
D35-522	hex bolt M8X16(D35,D45,D55)
D35-523	limit switch support(D35,D45,D55)

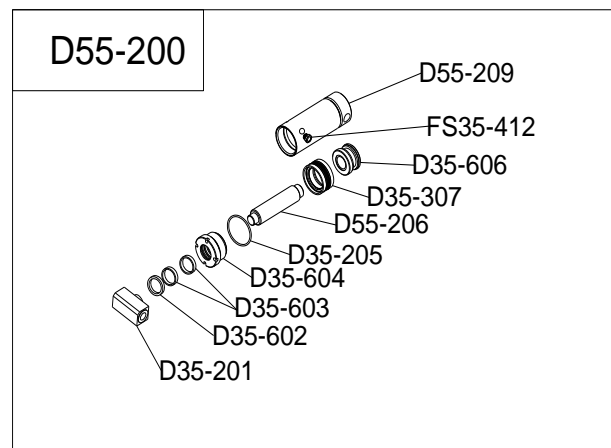
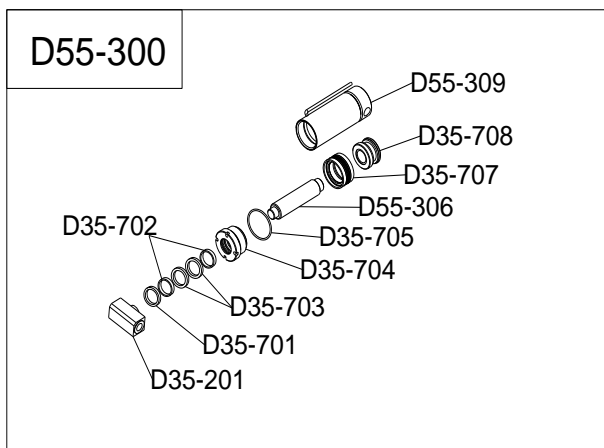

D35-201	oil cylinder support block(sub machine) (D55)
D35-602	dust-proof ring $\varnothing 50 \times 58 \times 6.5$ (D55)
D35-603	wear ring(D55)
D35-604	sub oil cylinder cover(sub machine) (D55)
D35-205	O-ring $\varnothing 80 \times 5$ (D55)
D55-206	sub oil cylinder piston rod(sub machine) (D55)
D35-307	combined seal ring $\varnothing 100 \times 75 \times 22.4$ (D55)
D35-606	sub oil cylinder piston (sub machine) (D55)
FS35-412	muffler G1/8(D55)
D55-209	Sub oil cylinder (sub machine) (D55)
D55-300	main oil cylinder complete(sub machine) (D55)
D35-701	dust-proof ring $\varnothing 66.3 \times 74.3 \times 6.5$ (D55)
D35-702	U-ring $\varnothing 66.3 \times 76.3 \times 11.5$ (D55)
D35-703	Wear ring(D55)
D35-704	main oil cylinder cover(sub machine) (D55)
D35-705	O-ring $\varnothing 120 \times 5$ (D55)
D55-306	main oil cylinder piston rod(sub machine) (D55)
D35-707	combined seal ring $\varnothing 120 \times 95 \times 22.4$ (D55)
D35-708	main oil cylinder piston (sub machine) (D55)
D55-309	main oil cylinder(sub machine) (D55) (D55)

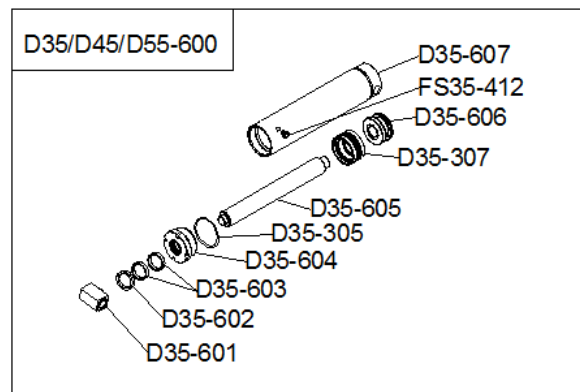
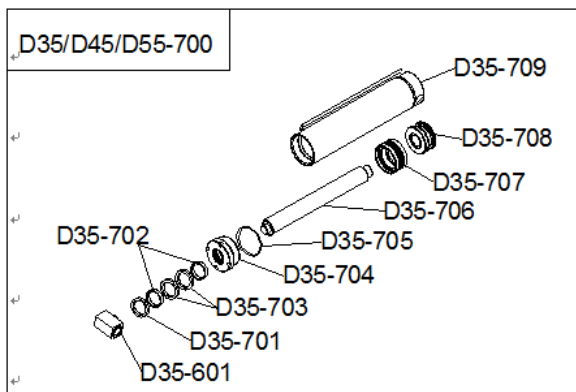
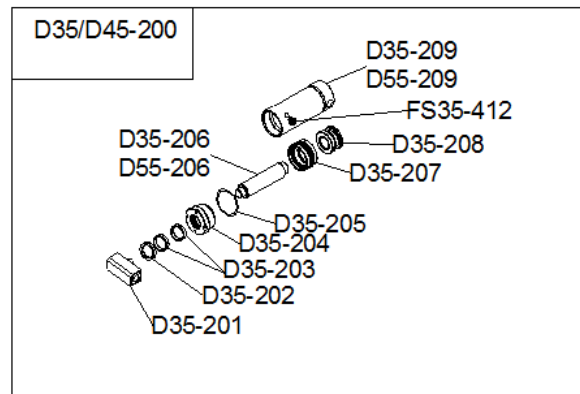
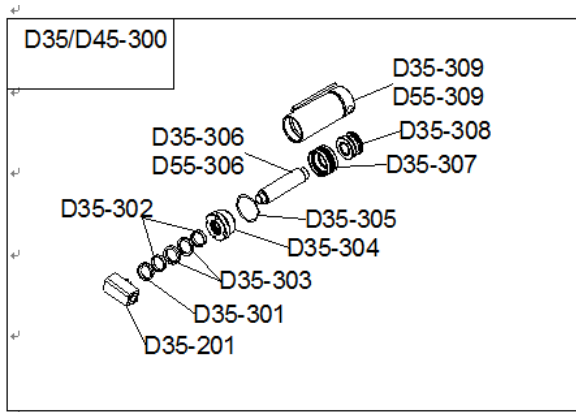



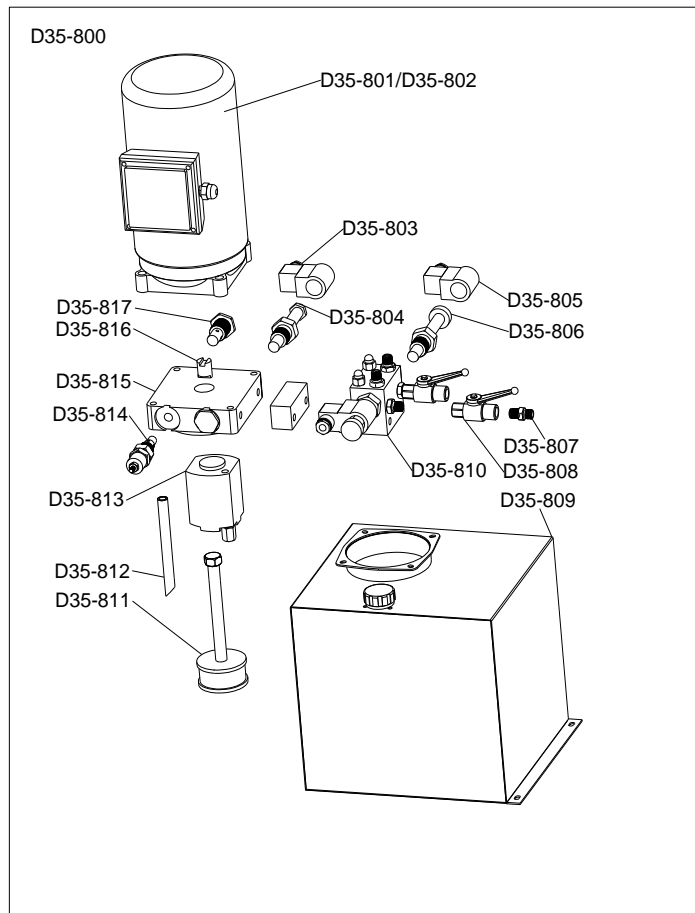









D35-201	oil cylinder support block(sub machine) (D35,D45)
D35-202	dust-proof ring 045X53X6.5(D35,D45)
D35-203	wear ring(D35,D45)
D35-204	sub oil cylinder cover(sub machine) (D35,D45)
D35-205	O-ring 080X5(D35,D45)
D35-206	sub oil cylinder piston rod(sub machine) (D35,D45)
D35-207	combined seal ring 080X60X22.4(D35,D45)
D35-208	sub oil cylinder piston (sub machine) (D35,D45)
FS35-412	muffler G1/8(D35,D45)
D35-209	Sub oil cylinder (sub machine) (D35,D45)
D35-301	dust-proof ring 060X68X6.5(D35,D45)
D35-302	U-ring 060x70x10.5(D35,D45)
D35-303	Wear ring(D35,D45)
D35-304	main oil cylinder cover(sub machine) (D35,D45)
D35-305	O-ring 0100X5(D35,D45)
D35-306	main oil cylinder piston rod(sub machine) (D35,D45)
D35-307	combined seal ring0100X75X22.4(D35,D45)
D35-308	main oil cylinder piston (sub machine) (D35,D45)
D35-309	main oil cylinder(sub machine) (D35,D45)
D35-601	oil cylinder support block(main machine) (D35,D45,D55)
D35-602	dust-proof ring 050X58X6.5(D35,D45,D55)
D35-603	wear ring(D35,D45,D55)
D35-604	sub oil cylinder cover(main machine) (D35,D45,D55)
D35-605	sub oil cylinder piston rod(main machine) (D35,D45,D55)
D35-606	sub oil cylinder piston (main machine) (D35,D45,D55)
D35-607	sub oil cylinder(main machine) (D35,D45,D55)
D35-701	dust-proof ring 066.3X74.3X6.5(D35,D45,D55)
D35-702	U-ring 066.3X76.3X11.5(D35,D45,D55)
D35-703	Wear ring(D35,D45,D55)
D35-704	main oil cylinder cover(main machine) (D35,D45,D55)
D35-705	O-ring 0120X5(D35,D45,D55)
D35-706	main oil cylinder piston rod(main machine) (D35,D45,D55)
D35-707	combined seal ring 0120X95X22.4(D35,D45,D55)
D35-708	main oil cylinder piston (main machine) (D35,D45,D55)
D35-709	main oil cylinder(main machine) (D35,D45,D55)



D35-800	Pump complete(D35,D45,D55)
D35-801	1 phase motor(D35,D45,D55)
D35-802	3 phase motor(D35,D45,D55)
D35-803	Lowng coil(D35,D45,D55)
D35-804	Lowng valve(D35,D45,D55)
D35-805	Raising coil(D35,D45,D55)
D35-806	Raising valve(D35,D45,D55)
D35-807	Oil hose union inner corn G1/4X19 17 R1/4X19(D35,D45,D55)
D35-808	Ball valve(D35,D45,D55)
D35-809	Oil tank(20L)(D35,D45,D55)
D35-810	Connecting block(D35,D45,D55)
D35-811	Suction oil hose(D35,D45,D55)
D35-812	Escape oil hose(D35,D45,D55)
D35-813	Gear pump(D35,D45,D55)
D35-814	Overflow valve(D35,D45,D55)
D35-815	Valve block(D35,D45,D55)
D35-816	Annectent spinde(D35,D45,D55)
D35-817	One-way valve(D35,D45,D55)

## 16. Accessories Packing List

Name	Pic	Spec.	Qty
1. High pressure oil hose		0.3m(103#)	1pc
		1.4m (110#)	2pcs
		1.6m (112#)	1pc
		3m (115#)	3pcs
		3.5m (117#)	1pc
2. Rubber mat		240mm*180mm*100mm	4pcs
3. Cylinder union		φ6*4	2pcs
4. Cylinder T-union		φ6*4	1pc
5. Foundation bolt		M16	16sets
6. Air hose		φ6*4 1600mm	2pcs
		φ6*4 3500mm	2pcs
		φ8*5 5500mm	1pc
7. Oil hose T-union		G1/4	1pc
8. Limit switch		AZ7312	1set
9. Limit switch support		including M8×16 bolt, flat washer and spring washer, M4×25 cross pan head screws, each for 2pcs	1set
10. Oil hose straight union		Inner cone at both sides G1/4 17 G1/4	2pcs
11. Use manual		(including instruction manual, certificate of soundness, warranty bill and packing list)	1set
12. Ribbon		4*200mm	20pcs
13. Front block car plate		Including front block car plate shaft and split pin	2sets



REACH  
GARAGE EQUIPMENT

[reachgarageequipment.com](http://reachgarageequipment.com)