



REACH
GARAGE EQUIPMENT

PL-FS35 FS40 FS50

FOUR POST LIFT

USER'S MANUAL V1.3 201902

INSTRUCTION & MAINTENANCE MANUAL



READ THIS ENTIRE MANUAL CAREFULLY AND COMPLETELY
BEFORE INSTALLATION OR OPERATION OF THE LIFT

POST LIFT INSTRUCTION MANUAL

INDEX	PAGE
1. Packing, transport and storage	- 3 -
1.1. Packing	- 3 -
1.2. Transport:	- 3 -
1.3. Storage:	- 4 -
2. Manual introduction	- 4 -
3. Description of the machine	- 4 -
3.1. Machine Application	- 4 -
3.2. Structure Features.....	- 5 -
3.3. Frame.....	- 5 -
3.4. Power unit	- 5 -
4. Specification.....	- 6 -
4.1. Main technical parameter	- 6 -
4.2. External dimension drawing.....	- 7 -
4.3. Types of vehicles suitable for	- 9 -
5. Safety.....	- 10 -
6. Installation	- 13 -
7. Adjustment	- 18 -
8. Operation.....	- 18 -
9. Maintenance and care.....	- 20 -
10. Trouble shooting table.....	- 21 -
11. Hydraulic pressure elements diagram.....	- 21 -
12. Oil hose connection diagram.....	- 23 -
13. Circuit drawing.....	- 24 -
14. Explosion drawing.....	- 26 -

1. Packing, transport and storage



All packing, lifting, handling, transport and unpacking operations are to be performed exclusively by expert personnel.

1.1. Packing

Standard equipment: hydraulic station and accessory, main and sub Platform, front and back crossbeam, front post, back post, left and right approaching ramp, rolling jack, total is 7 pieces.

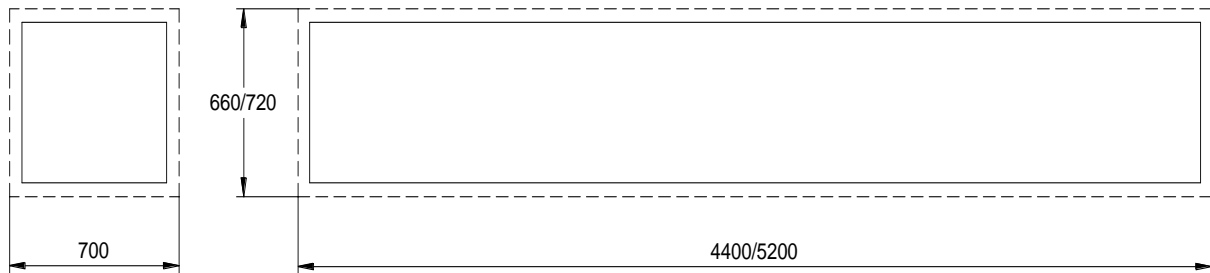

Picture 1

1.2. Transport:



Packing can be lifted or moved by lift trucks, cranes or bridge cranes. In case of slinging, a second person must always take care of the load, in order to avoid dangerous oscillations.

During loading and unloading operation, goods must be handled by vehicles or ships.

At the arrival of the goods, verify that all items specified in the delivery notes are included. In case of missing parts possible defects or damage may due to transport operations.

If finding missing parts, possible defects or damage due to transport, one should examine damaged cartons to verify the condition of damaged goods and missing parts, also the person in charge or the carrier must be immediately informed.



The machine is heavy goods! Don't take manpower load and unload and transporting way into consideration, the safety of working is important.

Furthermore, during loading and unloading operation goods must be handled as shown in the picture. (Picture 2)

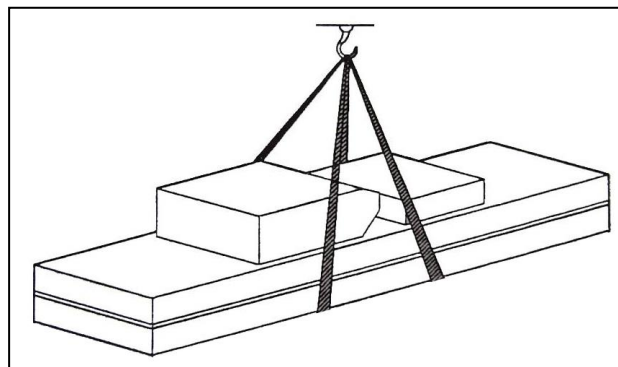

Picture 2 (Goods-lifted)

1.3.Storage:

- The machine equipment should be stocked in the warehouse, if stocked outside should do the disposal well of waterproof.
- Use box truck in the process of transport, use container storage when shipping.
- The control box should be placed perpendicularly during the transport; and prevent other goods from extrusion.
- The temperature for machine storage : -25°C-- 55°C

2. Manual introduction



This manual has been prepared for workshop personnel expert in the use of the lift operator and technicians responsible for routine maintenance fitter.

Workers should read the <<Instruction & Maintenance Manual>> carefully before carrying out any operation with the lift. This manual contains important information regarding:

- The personal safety of operators and maintenance workers.
- Lift safety.
- The safety of lifted vehicles.



Several tips should be done by the operator as follow:

- 1.Well conserving the manual. Manufacturer owns the right to make little change for the manual owing to the improvement of technology.
- 2.Good disposal the used oil.
- 3.The machine must be demolished by authorized technicians, just like for assembling

3. Description of the machine

3.1. Machine Application

Four post lift (for four wheel alignment purpose) is suitable for use in four wheel alignment, vehicle tests, maintenance and care for various types of small automobiles.



Lifts are designed and built to lift vehicles and hold them in the elevated position in an enclosed workshop. All other uses of the lifts are unauthorized. In particular, the lifts are not suitable for:

- Washing spray work;
- Use in outdoors;
- Creating raised platforms for personnel or lifting personnel;
- Use as a press for crushing purposes;
- Use as elevator;
- Vehicle with severely tilted or bent frame, or with deformed wheels.



The manufacturer is not liable for any injury to persons or damage to vehicles and other property caused by the incorrect and unauthorized use of the lifts.

3.2. Structure Features

- imported electric components.
- the alignment level of the lift can be adjusted in high precision, which is the ideal equipment for four-wheel alignment.
- The position of the front wheel turning table (optional part) is adjustable so that the side slide plate can be fit for more cars.
- Device performs stable and liable work with anti-breaking rope safety insurance.
- with second lifting trolley guide rail and can add a rolling jack.

Safety lock structure

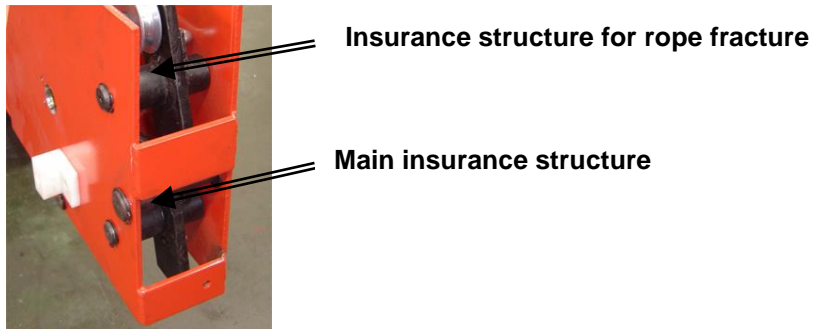

Picture 3

3.3. Frame

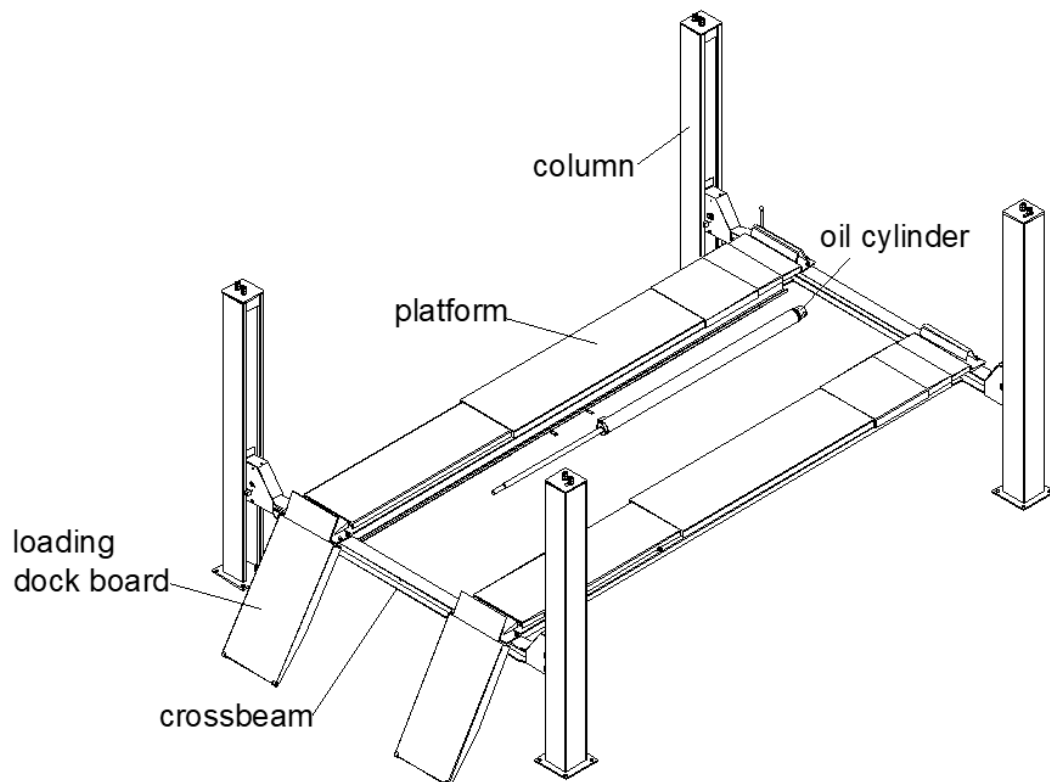

Picture 4

3.4. Power unit

Under the control box is hydraulic oil tank and hydraulic pump, valve and other control system. On the control box is electrical system.

Function of each valve on the power unit	
Name	Function
Gear pump	Extract hydraulic oil and provide high pressure.
Connecting block	Connect the motor and the gear pump.
Motor	Provide power for the gear pump.
Overflow valve	Adjust oil pressure.
Throttle valve	Adjust the speed of falling.
Lowering solenoid valve	Control flow of the hydraulic oil.
One-way valve	Control the one-way flow of hydraulic oil.

Table 1

4. Specification

4.1.Main technical parameter

MODEL	3.5T	4T	5T
Drive	Electrical hydraulic		
Max lift weight	3500kg	4000kg	5000kg
Lift height	1750mm		
Platform initial height	225mm	250mm	
Platform length	4250mm		5190mm
Platform width	530mm		
Lifting time	≤45S		≤55S
Lowing time	≤45S		≤55S
Overall width	3140mm		3340mm
Overall length	5260mm		6190mm
Power	3/N/PE~380V, 50Hz, 16A		
Hydraulic oil	10L corresponds to wearable hydraulic oil		
Rolling Jack lifting Weight	2000kg/3000kg		
Rolling jack lifting height	320mm		
Rolling jack lifting length	780-1600mm		
Rolling jack wheel distance	790-1040mm		
Rolling jack lifting time	Electrical RJ≤5s Manual or pneumatic RJ ≤20s		
Rolling jack lowering time	≤10S		
temperature	5-40℃		
Moist	30-95%		
Noisy	<76db		
Storage temperature	-25-55℃		
Optional	Rolling jack		

Table 2

4.2 External dimension drawing

PL-FS35/FS40/FS50

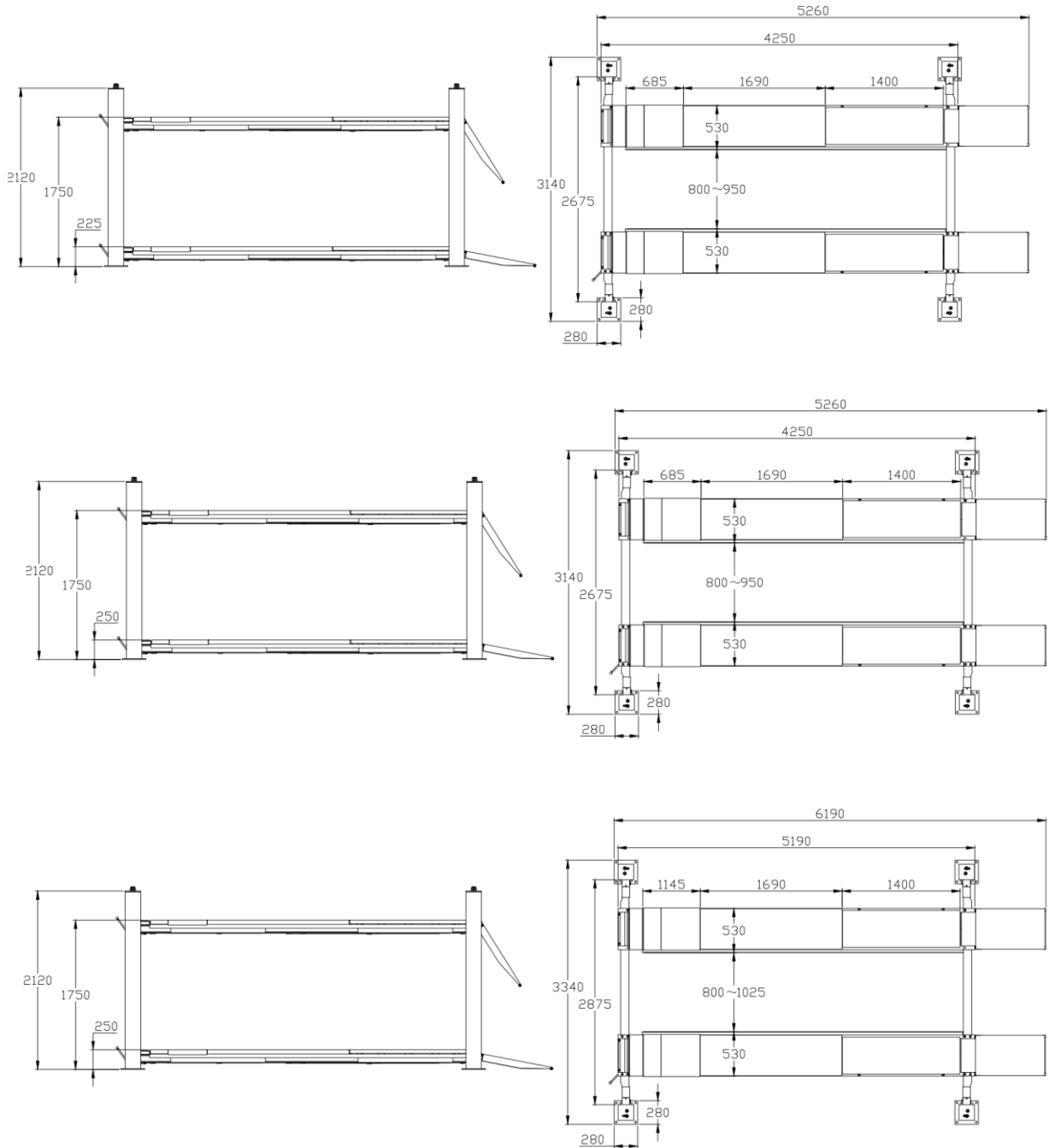

Picture 5(lift dimension picture)

NOTE: To install the lift it is necessary to execute suitable foundations with the following characteristics:

- Portland cement with strength grade above C20, the drying days are 15 days.
- thickness of concrete \geq 150mm, the levelness of whole length \leq 10mm



The thickness and levelness of the base concrete are essential and the levelness adjustment ability of the machine itself cannot be relied upon to excessively.

Types of vehicle with overall dimensions are suitable for being lifted.

4.3. Types of vehicles suitable for

Lift is suitable for virtually all vehicles with total weight of no more than 3500kg/4000kg/5000kg and with dimensions not exceeding the below data.

The following diagrams illustrate criteria used to define the operating limits of the lift.

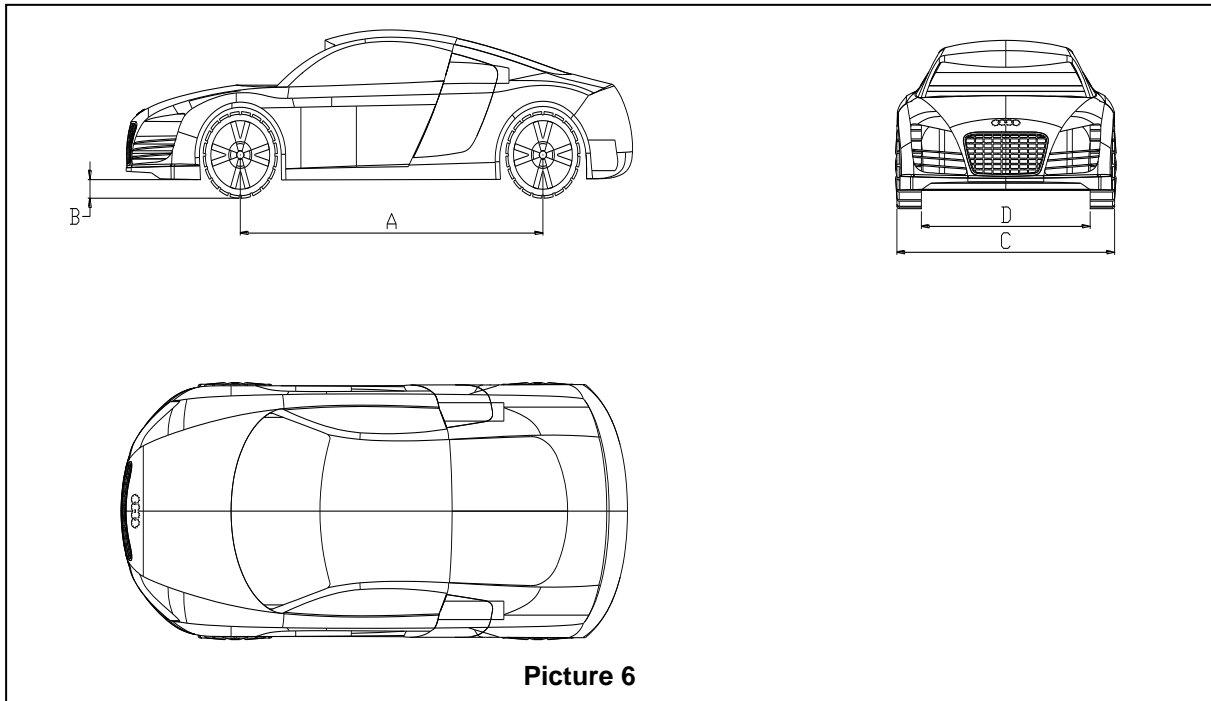

Picture 6

	3.5T/4T/5T	
	Min.(mm)	Max.(mm)
A	2300	3500/4000/4500
B	110	
C		2000
D	900	



Caution: The lower parts of the vehicle under-body could interfere with structural parts of the lift, take particular parts of the sports car.

The lift will also handle customized or non-standard vehicles, provided they are within the maximum specified carrying capacity.

Also the personnel safety zone must be defined in relation to vehicle with unusual dimensions.



Read this chapter carefully and completely since important information for the safety of the operator or others in case of improper use of the lift is included.

In the following text there are clear explanations regarding certain situations of risk or danger that may arise during the operation or maintenance of the lift, the safety device installed and the correct use of such systems, residual risks and operative procedures to use (general specific precautions to eliminate potential hazards).



Lifts are designed and built to lift vehicles and hold them in the elevated position in an enclosed workshop. All other uses of the lifts are unauthorized. In particular, the lifts are not suitable for:

- Washing spray work;
- Use in outdoors;
- Creating raised platforms for personnel or lifting personnel;
- Use as a press for crushing purposes;
- Use as elevator;
- Vehicle with severely tilted or bent frame, or with deformed wheels.



The manufacturer is not liable for any injury to persons or damage to vehicles and other property caused by the incorrect and unauthorized use of the lifts.

During lifting and descent, the operator must remain in the control station as the diagrams illustrated.

As the diagrams illustrated, the presence of persons inside the danger zone indicated is strictly prohibited. During operations persons are admitted to the area beneath the vehicle only when the vehicle is already in the elevated position, when the platforms are stationary, and when the mechanical safety devices are firmly engaged (e.g.: the safety gear is completely locked).



Do not use the lift without protection devices or with the protection devices inhibited.

Failure to comply with this regulation can cause serious injury to persons, and irreparable damage to the lift and the vehicle being lifted.

5. Safety

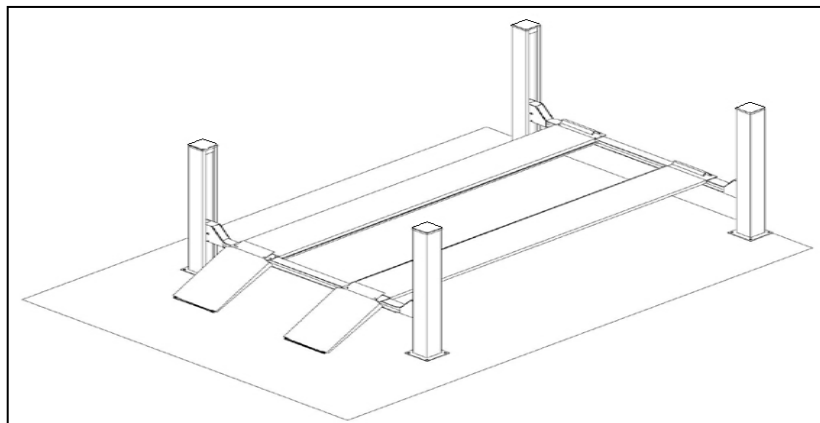

Picture 7



General precautions

The operator and the maintenance fitter are required to observe the prescriptions of safety regulation in force in the country of installation of the lift.

Furthermore, the operator and maintenance fitter must:

- Always work in the stations specified and illustrated in this manual;
- Never remove or deactivate the guards and mechanical, electrical, or other types of safety devices;
- Read the safety notices placed on the machine and the safety information in this manual.



In the manual all safety notices are shown as follows:

Warning: indicates following operations that are unsafe and can cause minor injury to persons and damage the lift, the vehicle or other property.



Risk and protection devices

For optimal personal safety and safety of vehicles, observe the following regulations:

- Do not enter the dangerous area while vehicle is being lifted. **(Picture 8)**
- Be sure to lift only approved vehicles, never exceed the specified carrying capacity, maximum height, and projection (vehicle length and width);
- Make sure that there is no person on the platforms during up and down movements and during standing. **(Picture 8)**

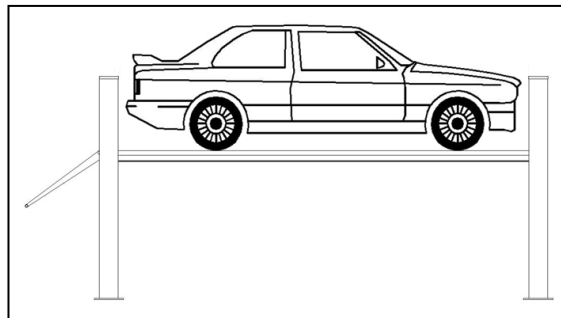

Picture 8



General risks for lifting or descent

The following safety equipments are used to protect over loading or the possibility of engine failure.

In the condition of over loading, the overflow valve will open and directly return oil to the oil tank. **(Picture 9)**



Picture 9

Risk of crushing



Possible if the operator controlling the lift is not in the specified position at the control panel.

When the platforms (and vehicle) are lowering the operator must never be partly or completely underneath the movable structure. Always remain in the control zone.

Risk of impact (Picture 10)



Caused by the parts of the lift or the vehicle that is positioned at head height.

When, due to operational reasons, the lift is stopped at relatively low elevations personnel must be careful to avoid impact with parts of the machine not marked with special labels.

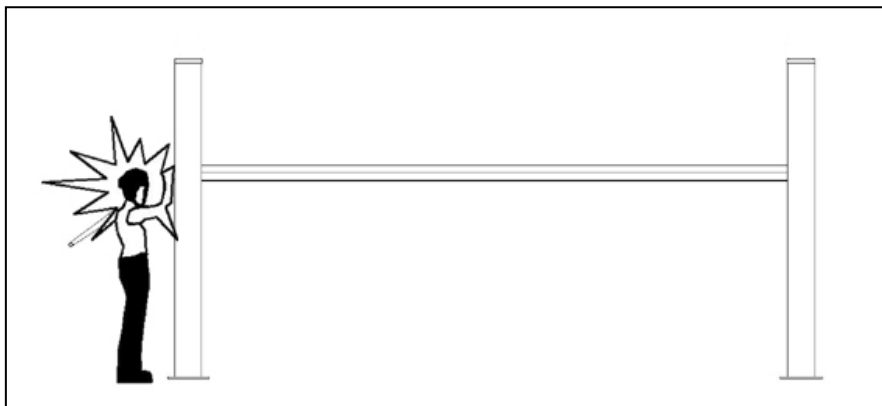

Picture 10



Risk of operator falling

No person is permitted in the platform or in the vehicle when the lift lifting and lowering,



Risk of vehicle falling from lift

This hazard may cause of incorrect positioning of the vehicle on the platforms, incorrect stopping of the vehicle, or vehicles of dimensions that are not compatible with the capacity of the lift.



Never attempt to perform test by driving the vehicle while it is on the platforms

Never leave objects in the lowering area of the movable parts of the lift.



Risk of slipping(Picture 11)

Caused by lubricant contamination of the floor around the lift.

The area beneath and immediately surrounding the lift and also the platforms must be kept clean.

Remove any oil spills immediately.

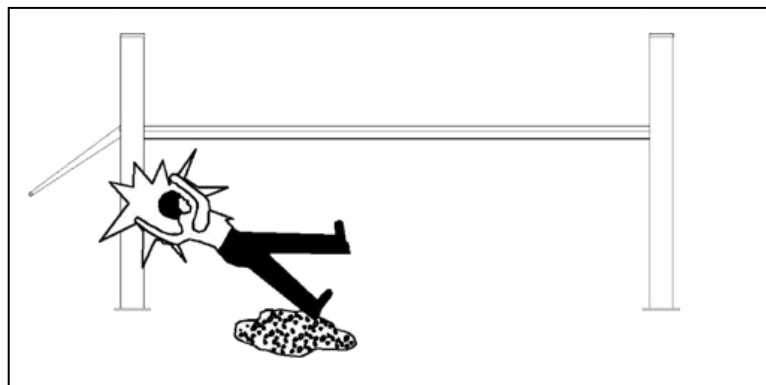

Picture 11

Risk of electric shock



Risk of electric shock in areas of the lift housing electrical wiring.

Do not use jets of water, steam solvents or paint next to the lift, and take special care to keep such substances clear of the electrical control panel.



The handling of safety devices is strictly forbidden. Never exceed the maximum carrying capacity of the lift, make sure the vehicles to be lifted have no load.

It is therefore essential to adhere scrupulously to all regulations regarding use, maintenance and safety contained in this manual.

6. Installation



Skilled and authorized personnel only should be allowed to perform these operations, follow all instructions shown below carefully, in order to prevent possible damage to the car lift or risk of injury to people.

Installation requirements (Picture 12)

The car lift must be installed according to the specified safety distances from walls must be 600 mm at least, taking into consideration of the necessary space to work easily. Further space for the control site and for possible runways in case of emergency is also necessary; the room must be previously arranged for the power supply. The room must be 4000 mm in height, at least, the car lift can be placed on any floor, as long as it is perfectly level and sufficiently resistant. (Concrete grade above C20, the thickness of concrete ≥ 150 mm)

-All parts of the machine must be uniformly lit with sufficient light to make sure that the adjustment and maintenance operations specified in the manual can be performed safely, and without areas of shadow, reflected light, glare and avoiding all situations that could give rise to eye fatigue.

-The lighting must be installed in accordance with the laws in force in the place of installation.

-the thickness and levelness of the base concrete are essential

-thickness of concrete ≥ 150 mm, the levelness of whole length ≤ 10 mm.

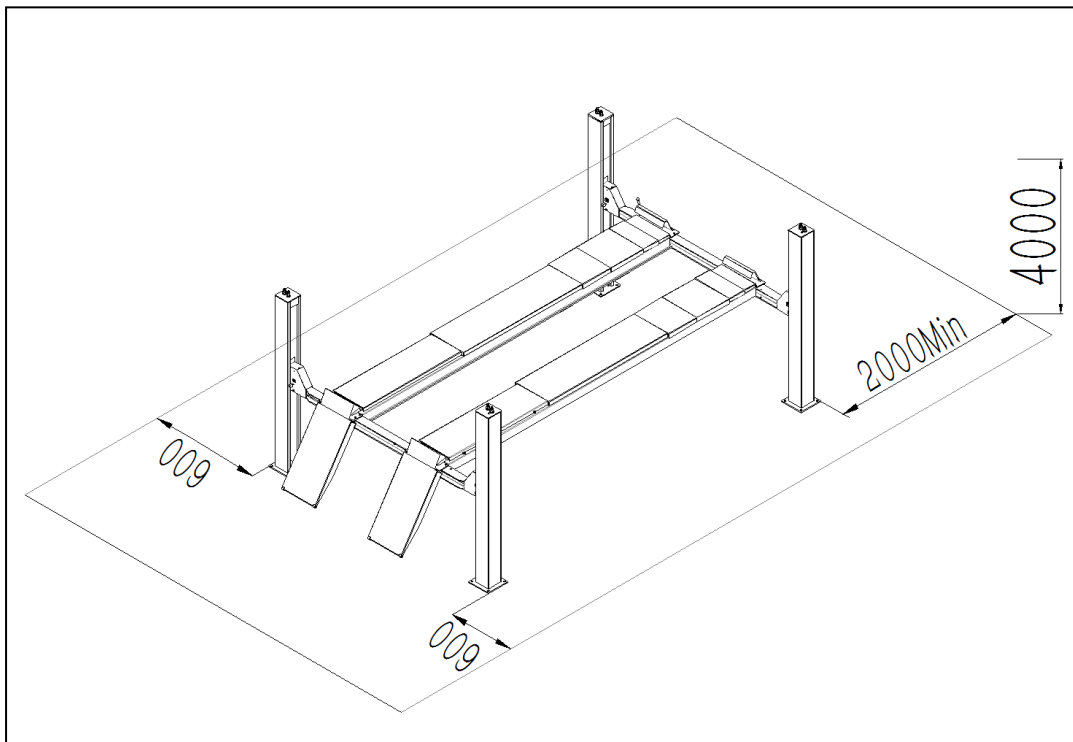

Picture 12

Installation scheme for four post lift

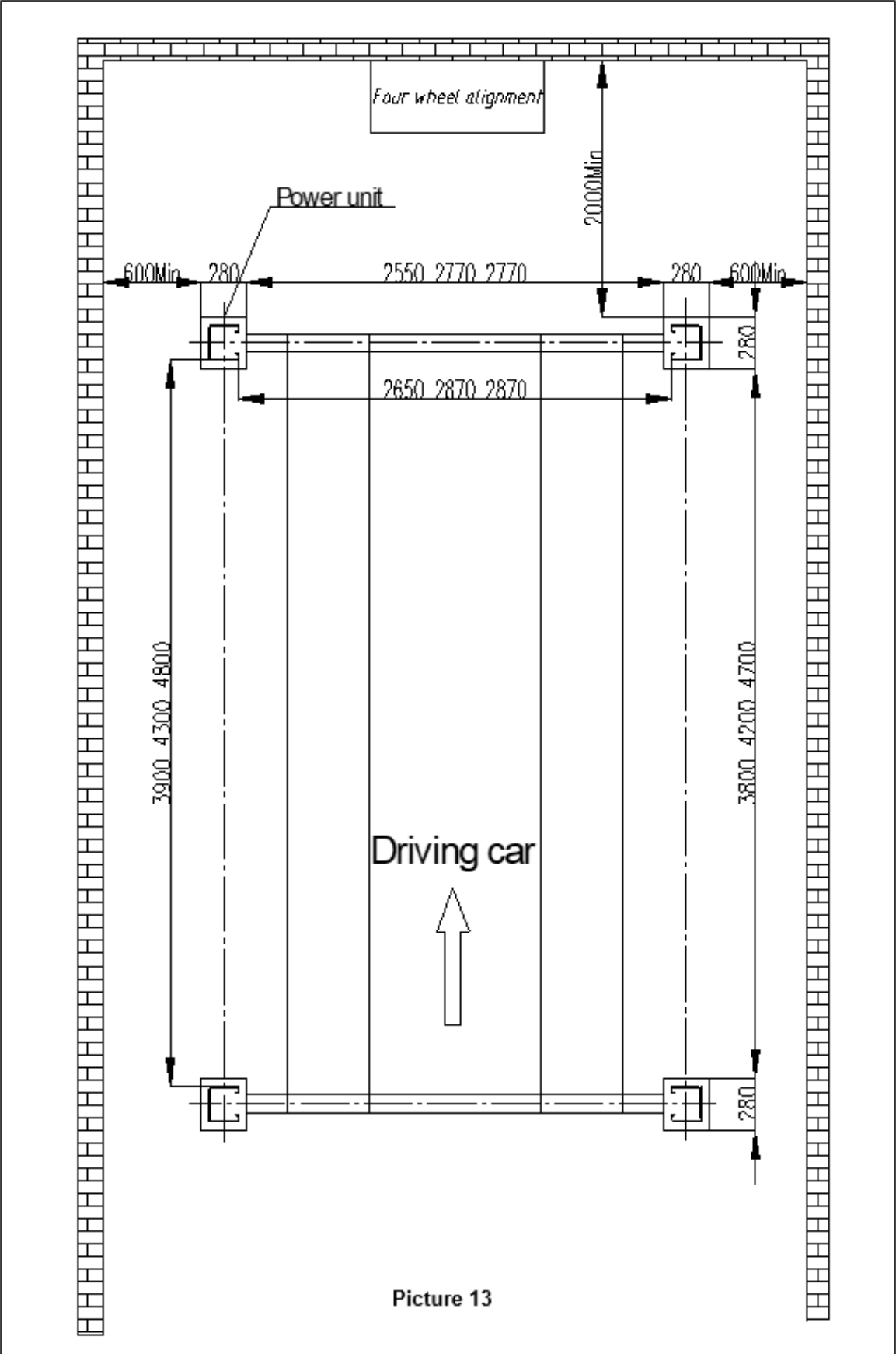

Picture 13

Crossbeam installation:

- fix the front and back crossbeam on the floor.
- Put a wood or an iron under the crossbeam in order to raise 100-300mm.
- fix eight nylon anti-crashes inner and outer of the crossbeam.

Platform installation:

- Put two platforms on the transom, the main platform should located on the left side of the moving vehicle direction, the sub-platform located on the right side, the rolling wheel notch on the platform should inside.
- check two platforms and the diagonal of two transom are straight, then put four posts on the side of the transom, and fix the nuts on the roof of the post with steel cable, put the safety teeth trough the limit axis, also fix the nuts on the roof of the post.

Steel cable connection:

- Unload the nuts of the steel cable, avoid the steel cables being twining with each other.
- The short steel cable goes through the groove of pulley on the left side. Loose the shaft of pulley inside the crossbeam. Install the shaft of pulley after finishing putting on the steel cable.

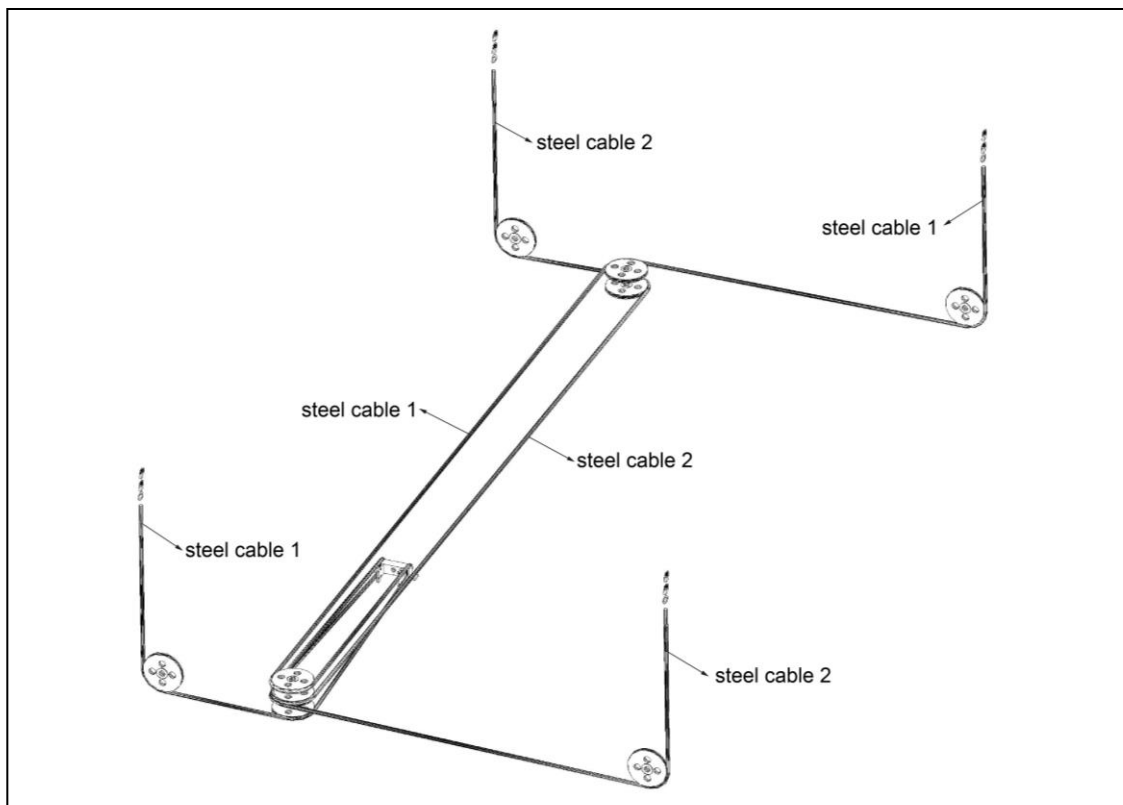

Picture 14

Post installation:

- Unload the screws under the insurance in the post.
- stick the column on the nylon block of the crossbeam, insert the insurance strip into the groove of crossbeam
- measuring the column and use the thick iron mat to make the column base plate vertical with the column.

Rolling jack installation:

- adjust the distance of the rolling jack; put the rolling jack between the slide track.
- adjust the sub Platform to make sure the sliding of the rolling jack.

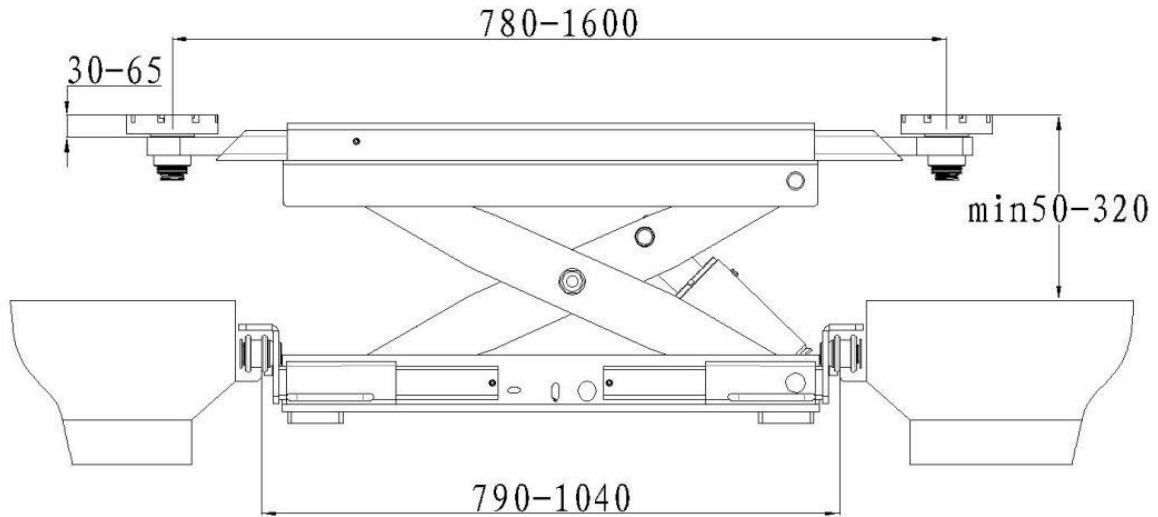

Picture 15

Line connection:

Connect the electrical and oil line according to the electric wiring diagram and oil line connection.



To avoid the unexpected lift closure due to mechanical safety device release insert wooden pieces in the inner part of the base frame.

Pay attention not to work under the lift until the hydraulic system has not been completely filled with hydraulic oil.

Electrical circuit connection:



According to the electric connection.

Skilled personnel only are allowed to perform the operations shown below.

-open the control box front cover

-connection of power supply: the 400 three-phase four-wires (4*1.5mm²) for power supply are connected to terminals 1#, 2#, 3#.The PE is connected to the ground wire. (Picture 16)

-Electric motor wire connection: connect the control box with U1 # 、 V1#、 W1# electric wire to motor wire box.

-therefore if you wish the lift to operate at 230V three-phase, change the connection on the transformer and motor.

(Picture 17)

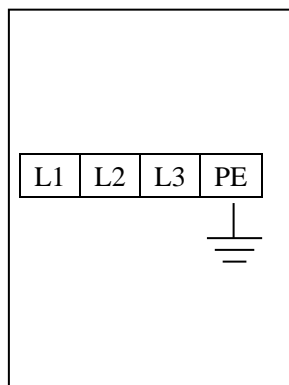

Picture 16

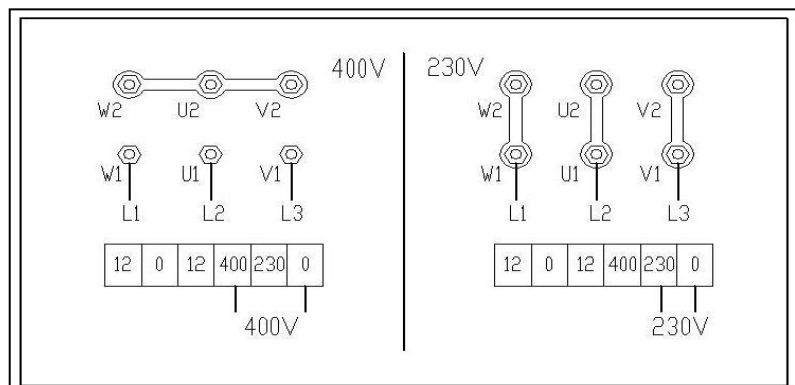

Picture 17

Hydraulic hoses connection:

Follow <<oil hose connection diagram >> to connect the hydraulic oil hoses
 Open the hydraulic oil tank, add 10L corresponds to wearable hydraulic oil into the oil tank, the hydraulic oil is provided by the user.



Make sure the clean of hydraulic oil, prevent any impurity into the oil line, lead the digest of the oil line and no working of the solenoid valve.

-turn on "power" switch, clicking the "up" button, check whether the motor turns clockwise (looking downward), if not , turn off "power" switch, change the phase of the motor.



When turn on power, there is high voltage in the control box, only authorized person can operate.

Main machine adjustment

- press "up" button SB1, lift crossbeam approximately 1000mm.
- press "down" button SB2, verify the safety instruction.
- press "down" button SB2, adjust the safety instruction on the frame of the crossbeam. Then lower the platform.

Rolling jack adjustment

- press the pneumatic switch on the pneumatic carriage, lift approximately 300mm.
- press the other side of pneumatic lift the safety rod of rolling jack, lower the rolling jack.
- press the other side of pneumatic pump, verify the insurance instruction.

Anchor bolts installation

- Fix the anchor bolts with a percussion electric drill (percussion drill bit is of 16), drill to 120mm hole and clean the hole.(Picture 20)
- Use light hammer to install the ground bolts into the hole (need not install the central expanded nail of ground bolts, install it after level adjustment.) (Picture 21)

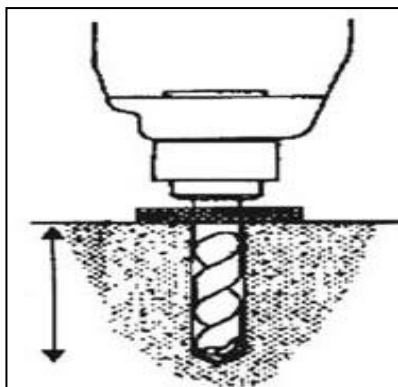

Picture 20

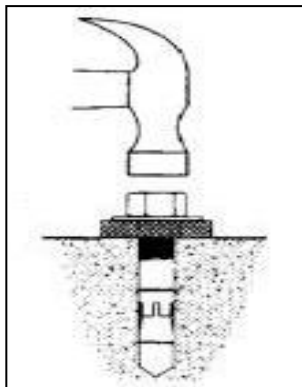

Picture 21

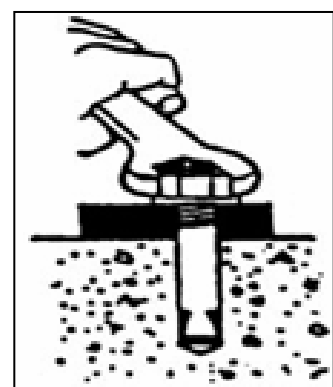

Picture 22

7. Adjustment

Level adjustment (Picture 23)

-adjust the level of the two front turntable and the slide plates on both sides at back with a leveling instrument.

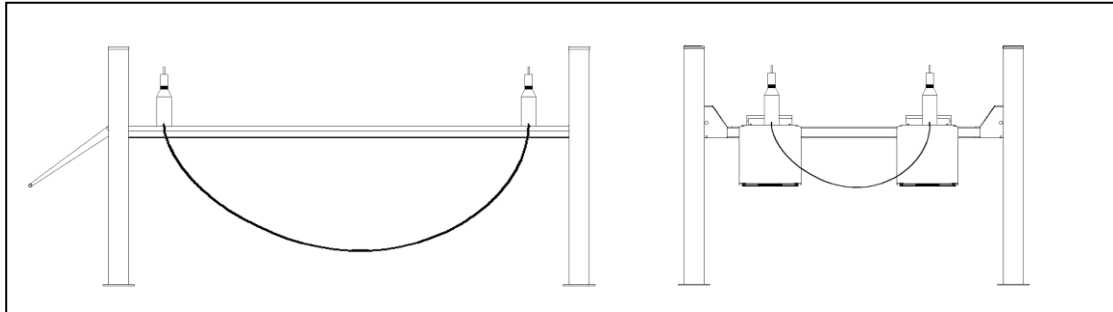

Picture 23

Insurance level adjustment.

- if the basement without parallel lead to the platform without parallel, adjust the height of the safety rod.
- lift the platform approximately 100mm; press “down” button let the insurance go into the same hole of insurance rod.
- loose the bolts on the bottom of column, observe the horizontal line and adjust the bolts on the insurance strip thread rod
- fix the insurance strip bolts and nuts after level adjustment.
- insert the anchor, use a heavy hammer to install the expansion bolts and screw down the screw cap

Steel cable adjustment

- lift the platform approximately 1000mm.
- observe the horizontal line and adjust the bolts on the steel cable thread rod inside the column.
- fix the steel cable bolts after level adjustment.

8. Operation

Only trained person can operate and check as follows:

- clear obstacles around before operation.
- during lifting or lowering, no person is allowed to stand near the two sides and beneath the machine, and no person is allowed on the two platform.
- avoid lifting super heavy vehicles or other thing.
- when lifting vehicle, the hand brake lever of the vehicle should be pulled, and the slide resistant triangle woods should be used.
- pay attention to the synchronization of the lifting and lowering. If any thing abnormal is found, stop the machine timely, check and remove the trouble.
- when locking the main machine, the two platforms should be kept at the same height.
- when the equipment has not used for a long time or over night, the machine should be lowered to the lowest position on ground, and remove vehicle, and cut off power supply.

Instructions on electric operation :(see the operation panel **Picture24**)

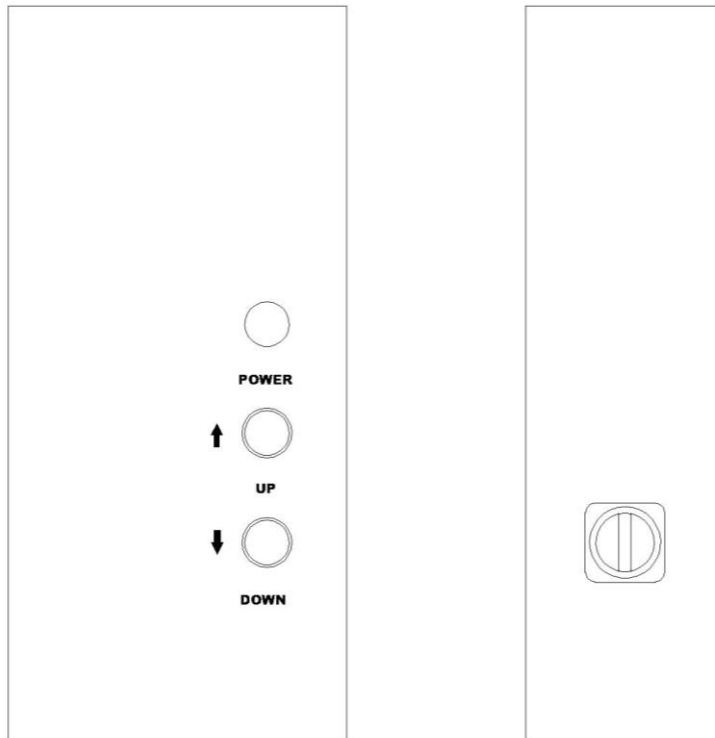

Picture 24

Lift the main machine:

- if equipped with electrical carriage, first turn the manual selector on “main machine” position.
- press “up” button SB1, oil pump works, and the platform lift.

Main machine locking

- single press “down” button, the platform lowers and the lift is locked.

Main machine lower

- first click press “up” button SB2 for 2-3s, then pull down the unlocking handle, press “down” button to lower the platform. (Picture 25)



Only authorized person can operate, doing alignment only after “locking” process.

Ordinary rolling jack lifting

- press the pneumatic switch on the pneumatic carriage, rolling jack is lift.
- Note: the speed of rolling jack is fast, cannot press the pneumatic switch continuously.

Ordinary rolling jack lowering

- press the other side of pneumatic lift the safety rod of rolling jack, lower the rolling jack.

Emergency manual operation for lowering (power failure)



When lowering through manual operation, should observe the condition of platform at any time because there is vehicle on the platform. If there is anything abnormal, screw down oil loop valve immediately.(refer to **Picture 26**)

The process of manual operation

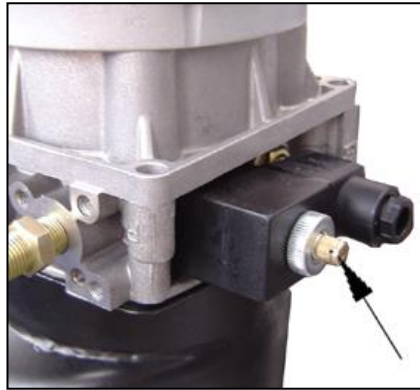

Picture 26

9.Maintenance and care

The maintenance and care of the lift must be operated by skilled person.

- the upper and lower sliding blocks must be cleared of foreign objects, and must be kept clean and lubricated.
- all bearings and hinges on this machine must be lubricated once a month
- the type of F4 of the four-wheel alignment should lubricate yearly.
- the hydraulic oil must be replaced once a year. The oil level should always be kept upper than limit position.
- check the steel line every three times and if there is something wrong, stop using, and tell the manufacture.
- the integration of the pneumatic system with an air treatment unit is suggested.

When change hydraulic oil, put machines to the lowest position, have the oil tank empty, when add new oil, should have the oil cleaned.

- if equipped with rolling jack, check the liability of the switch.

10. Trouble shooting table

Trouble	Cause and Phenomena	Resolutions
The motor does not run in lifting operation.	① Connection of power supply wires or zero wire is not correct.	Check and correct wire connection.
	② The AC contactor in the circuit of the motor does not pick up.	If the motor operates when forcing the contactor down with an isolation rod, check the control circuit. If the voltage at two ends of the contactor coil is normal, replace the contactor.
In lifting operation, the motor runs, but there is no lifting movement.	① The motor turns reverse.	Change the phases of the power supply wires.
	② It is normal while lifting with light load but abnormal while lifting with heavy load.	The set safe pressure of the over-flow valve may be increased by turning the set knob right ward slightly. The spool of the lowering solenoid valve is stuck by dirt. Clean the spool.
	③ The amount of hydraulic oil is not enough.	Add hydraulic oil.
	④ The "operation stop valve" is not open.	Turn right and open the "Operation stop valve" and supply hydraulic oil to main oil cylinder.
When press "Lower" button, the machine is not lowered.	① The safety pawl are not released form the safety teeth.	First lift a little and then lowering.
	② The safety pawl is not lifted.	The air pressure is not enough or the safety pawl is stuck.
	③ The solenoid air valve does not work.	If the solenoid air valve is energized, but does not open the air loop, check or replace the solenoid air valve.
	④ The lowering solenoid valve is energized but does not work.	Check the plug and coil of the lowering solenoid valve and check the right turn tightness of its end copper nut and so on.
	⑤ The hydraulic oil has too high viscosity or frozen, deteriorated (in Winter).	Replace with 20# hydraulic oil in accordance with the instruction book.
The machine lowers extremely slowly under normal loads.	① The "antiknock valve" for preventing oil pipe burst is blocked.	Remove or close air supply pipe and thus lock the safety pawl of the machine without lifting of the safety pawl. Remove the "antiknock valve" from the oil supply hole at the bottom of the oil cylinder, and clean the "antiknock valve".
	② Oil leakage on oil pipe or at its connections.	Tighten oil pipe connections or replace oil seals and then make-up oil and adjust levelness.
	③ The "oil make-up stop valve" can not be closed tightly and almost make-up oil and adjust every day.	Replace oil make-up stop valve and then make-up oil and adjust.
	④ The base or the machine is twisted.	Adjust again the levelness of the machine, and fill or pad the base.

11. Hydraulic pressure elements diagram

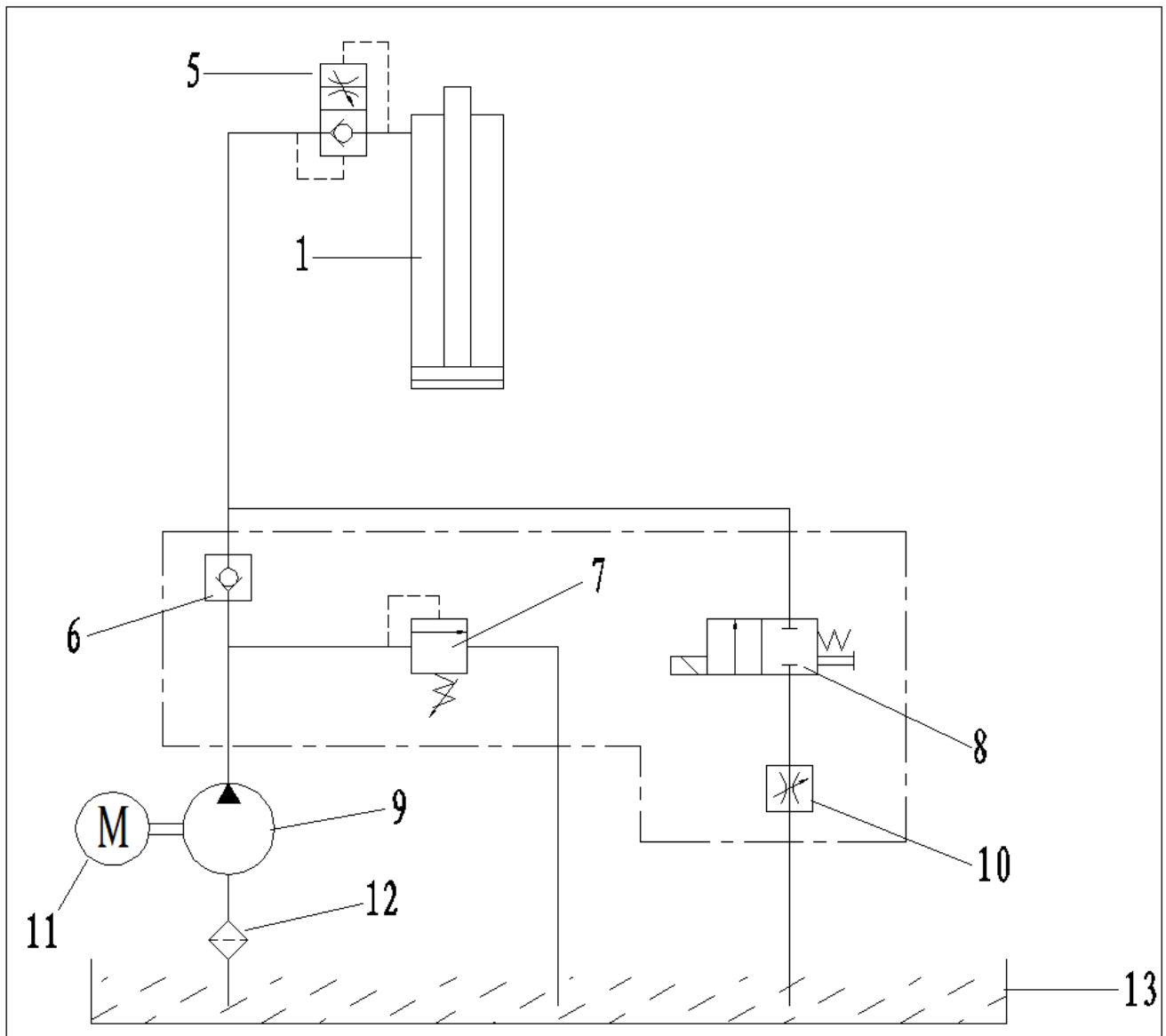

- 1.main platform
- 2.rolling jack
- 4.selector valve
- 5.one-way valve
- 6.overflowing valve
- 7.descent valve
- 8.throttling valve
- 9.gear pump
- 10.pump motor
- 11.filter
- 12.oil tank

12. Oil hose connection diagram

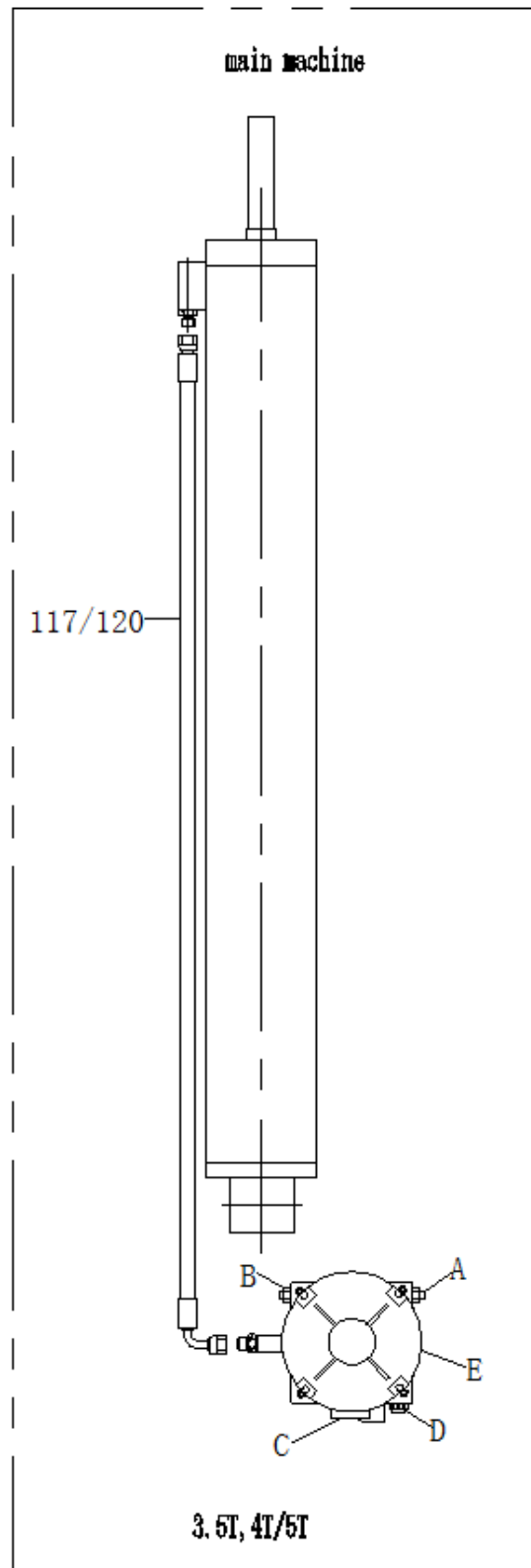

1. 117#~120# High pressure pipe
2. A: Over flow valve; B: Plug; C: descent valve; D: One-way valve; E: Motor

13. Circuit drawing

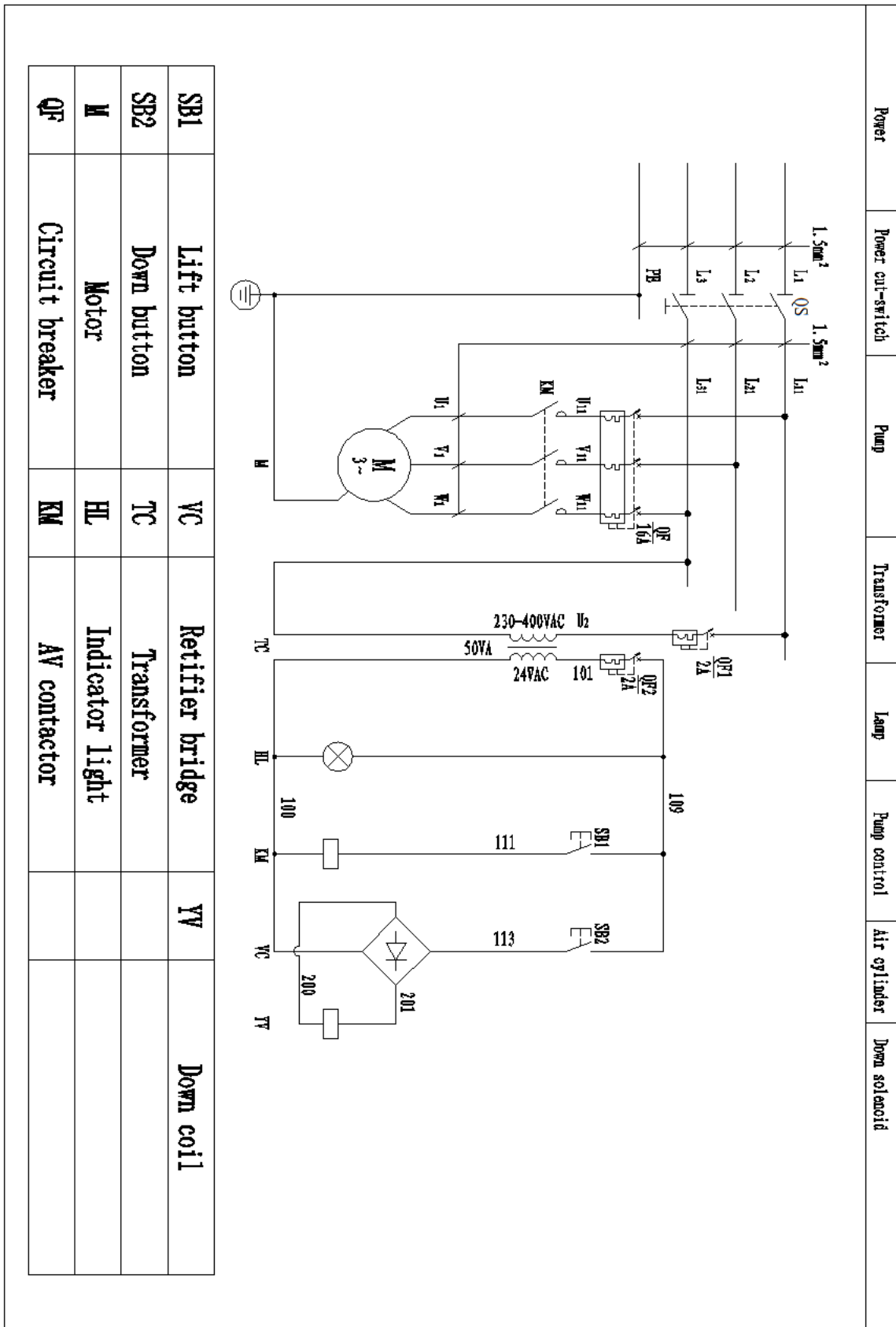

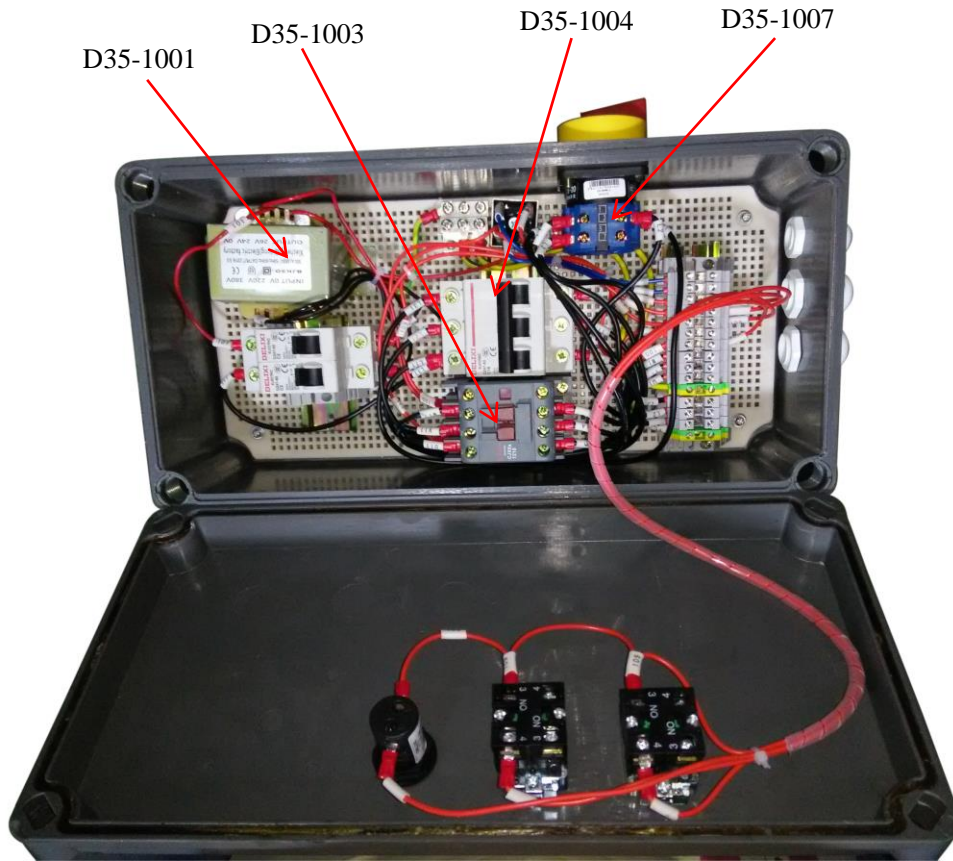

D35-1001	Transformer
D35-1003	AC contactor
D35-1004	Circuit breaker
D35-1007	Power switch

14. Explosion drawing

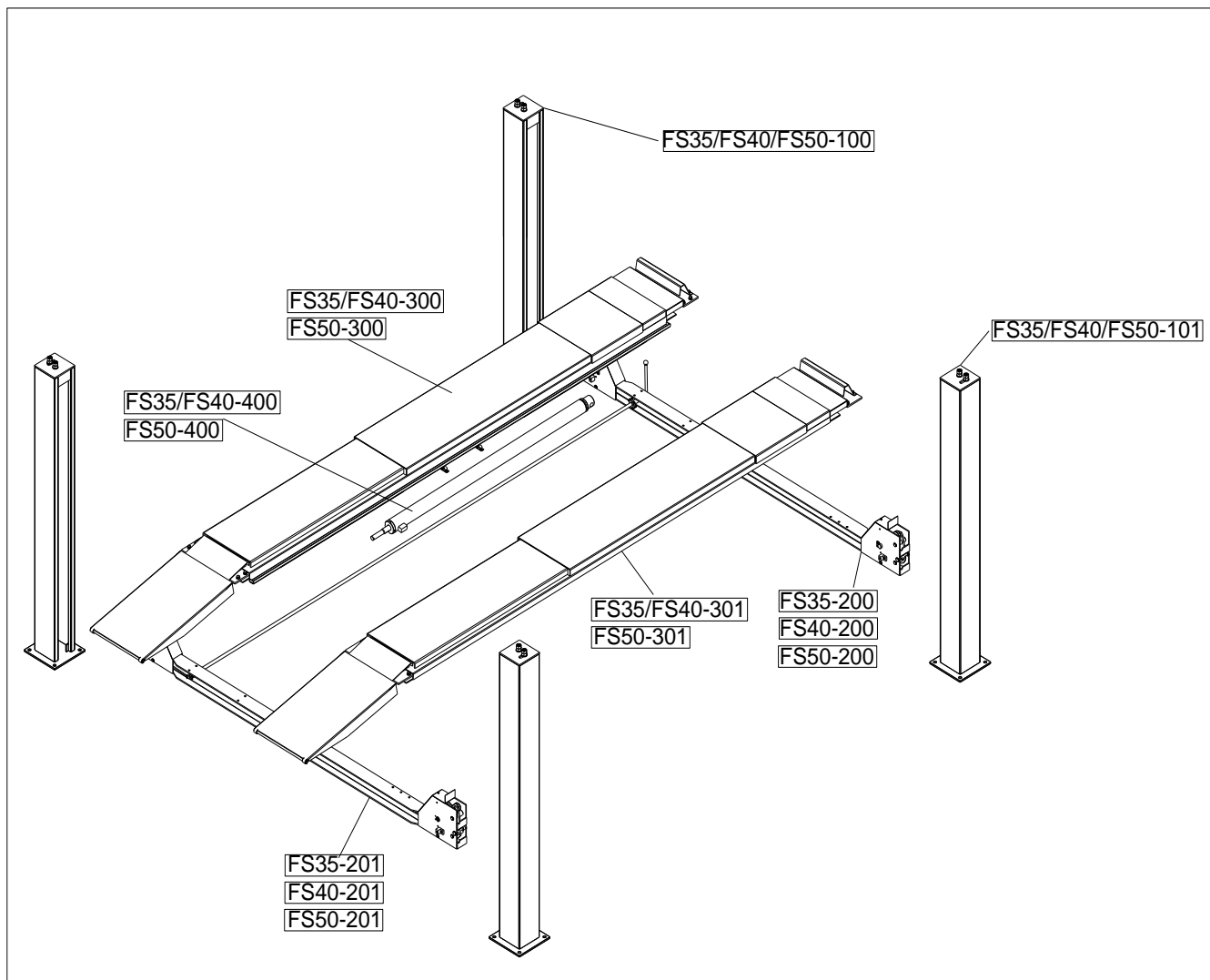

FS35/FS40/FS50-100	Complete column 1 assembly(FS35,FS40,FS50)
FS35/FS40/FS50-101	Complete column 2 assembly(FS35,FS40,FS50)
FS35-200	Crossbeam 1 assembly(FS35)
FS40-200	Crossbeam 1 assembly(FS40)
FS50-200	Crossbeam 1 assembly(FS50)
FS35-201	Crossbeam 2 assembly(FS35)
FS40-201	Crossbeam 2 assembly(FS40)
FS50-201	Crossbeam 2 assembly(FS50)
FS35/FS40-300	Platform 1 assembly(FS35,FS40)
FS50-300	Platform 1 assembly(FS50)
FS35/FS40-301	Platform 2 assembly(FS35,FS40)
FS50-301	Platform 2 assembly(FS50)
FS35/FS40-400	Oil cylinder assembly(FS35,FS40)
FS50-400	Oil cylinder assembly(FS50)

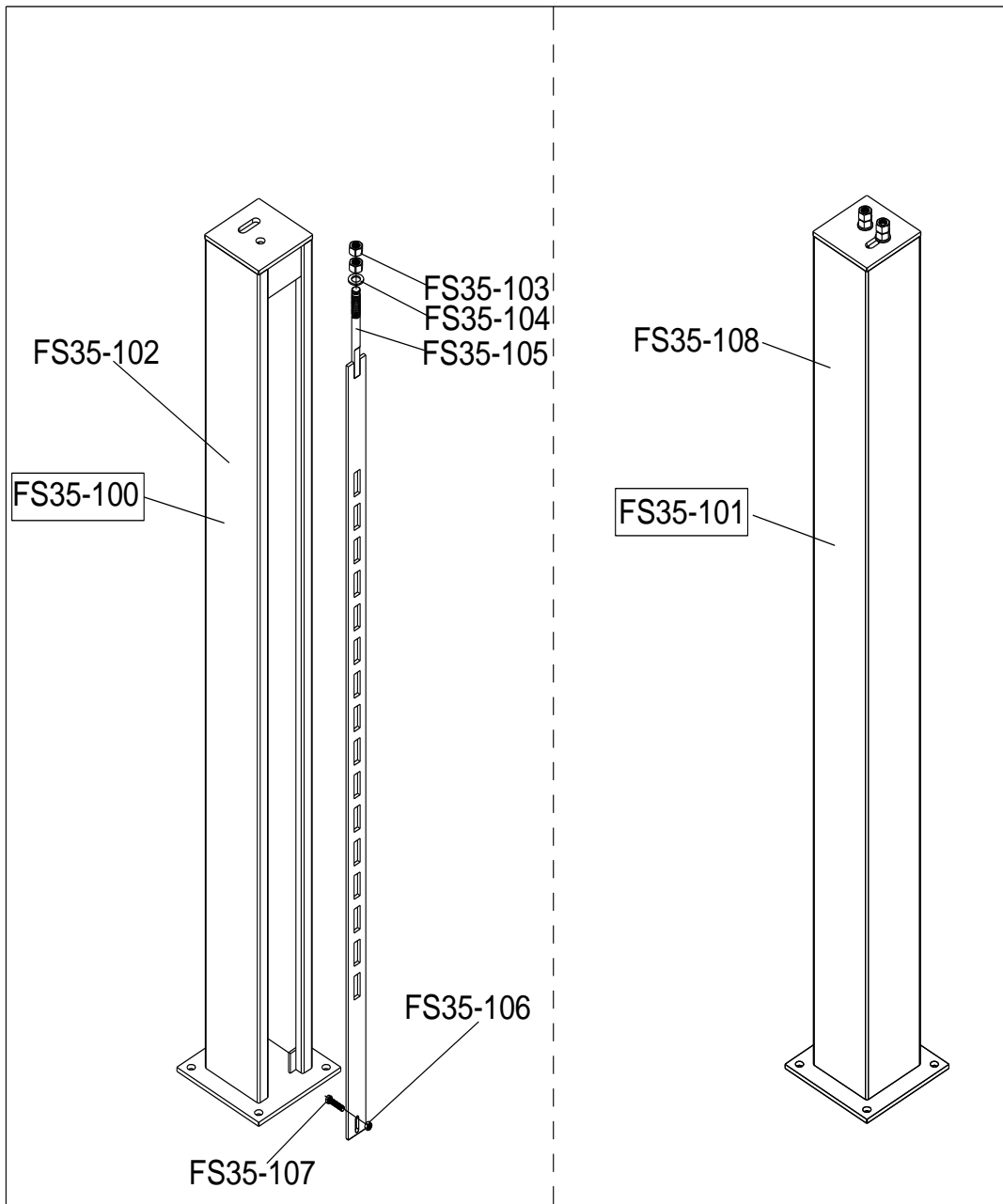

FS35-102	ZZ-304-010000-Z	column (FS35,FS40,FS50)
FS35-103	B-004-200001-1	hex nut M20(FS35,FS40,FS50)
FS35-104	B-040-223730-1	flat washer(FS35,FS40,FS50)
FS35-105	ZZ-304-110000-Z	insurance strip(FS35,FS40,FS50)
FS35-106	B-004-100001-1	hex nut M10(FS35,FS40,FS50)
FS35-107	B-009-001030-3	Cup head square neck bolts M10X30(FS35,FS40,FS50)
FS35-108	ZZ-304-010000-Z	column 2(FS35,FS40,FS50)

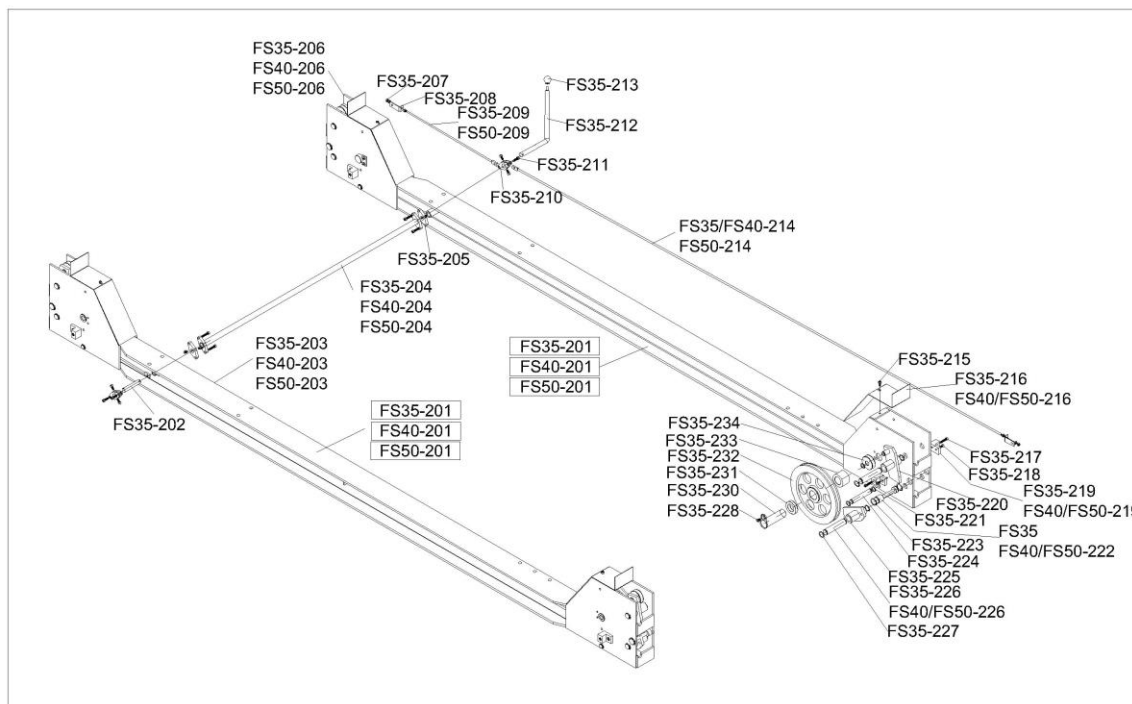

FS35-202	ZX-304-002500-0	drive shaft(FS35,FS40,FS50)
FS35-203	ZZ-304-020000-Z	crossbeam2(FS35)
FS40-203		crossbeam2(FS40)
FS50-203		crossbeam2(FS50)
FS35-204	ZZ-304-080000-Z	drive rod(FS35)
FS40-204		drive rod(FS40)
FS50-204		drive rod(FS50)
FS35-205	ZX-304-002400-0	Ring flange(holes) (FS35,FS40,FS50)
FS35-206	ZZ-304-020000-Z	crossbeam1 (FS35)
FS40-206		crossbeam1 (FS40)
FS50-206		crossbeam1 (FS50)
FS35-207	B-004-060001-1	hex nut M6(FS35,FS40,FS50)
FS35-208	ZX-304-003000-0	Connecting rod support(FS35,FS40,FS50)
FS35-209	ZZ-304-130000-Z	short pull rod(FS35,FS40,FS50)
FS35-210	ZX-304-002600-0	Ring flange(grooved) (FS35,FS40,FS50)
FS35-211	B-010-060201-0	hex socket head cap screw M6X20(FS35,FS40,FS50)
FS35-212	ZX-304-002700-0	drive handle(FS35,FS40,FS50)
FS35-213	S-410-008032-0	handle ball(FS35,FS40,FS50)
FS35-214	ZZ-304-120000-Z	long pull rod(FS35)
FS40/FS50-214		long pull rod(FS40,FS50)
FS35-215	B-010-060121-0	hex socket head cap screw M6X12(FS35,FS40,FS50)
FS35-216	ZZ-304-001700-0	crossbeam protective plate(FS35)
FS40/FS50-216		crossbeam protective plate(FS40,FS50)

FS35-217	B-010-060301-0	hex socket head cap screw M6X30(FS35,FS40,FS50)
FS35-218	B-017-060161-0	cross sunk head screw M6X18(FS35,FS40,FS50)
FS35-219	ZG-304-000600-0	Limit gommures(FS35)
FS40/FS50-219		Limit gommures(FS40,FS50)
FS35-220	ZX-304-090000-Z	Upper insurance block(FS35,FS40,FS50)
FS35-221	B-055-160001-0	shaft snap ring ϕ 16(FS35,FS40,FS50)
FS35-222	ZX-304-001300-0	Limit shaft of insurance strip (FS35)
FS40/FS50-222		Limit shaft of insurance strip(FS40,FS50)
FS35-223	B-055-240001-0	shaft snap ring ϕ 24(FS35,FS40,FS50)
FS35-224	ZX-304-004200-0	Limit shaft of crossbeam steel cable ϕ 16x100mm(FS35,FS40,FS50)
FS35-225	ZX-304-100000-Z	downward insurance block(FS35,FS40,FS50)
FS35-226	ZX-304-001100-0	Insurance block stationary shaft(FS35,FS40,FS50)
FS40-236		Insurance block stationary shaft(FS35,FS40,FS50)
FS35-227	B-055-200001-0	shaft snap ring ϕ 20(FS35,FS40,FS50)
FS35-228	B-017-080121-0	cross countersunk head screw M8X12(F35,F40,F50)
FS35-230	ZX-304-000700-0	Guide pulley stationary shaft (FS35)
FS35-231	ZZ-304-000100-0	Rubber mat (thin) (FS35,FS40,FS50)
FS35-232	ZG-304-003600-0	Steel cable pulley (single groove) 1(FS35,FS40,FS50)
FS35-233	ZZ-304-000200-0	Rubber mat (thick) (FS35,FS40,FS50)
FS35-234	ZX-304-002100-0	Upper insurance block pulley(FS35,FS40,FS50)

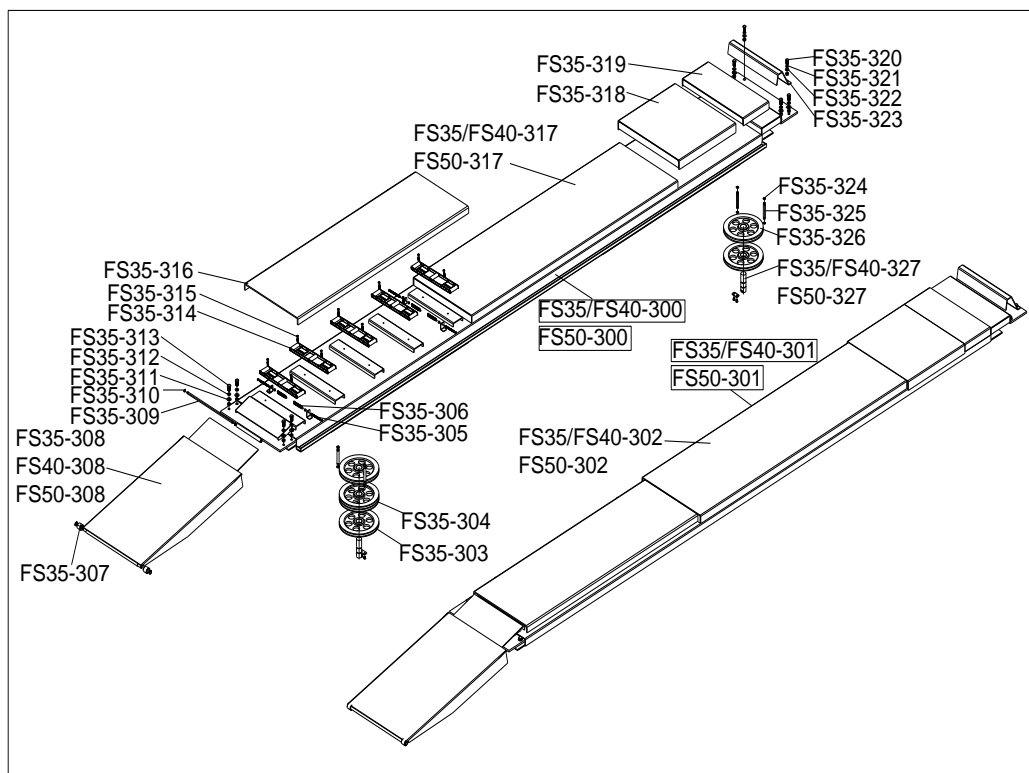

FS35-302	ZZ-304-040000-Z	platform 2(FS35)
FS40/FS50-302		platform 2(FS40,FS50)
FS35-303	ZG-304-003400-0	Steel cable pulley (single groove) 2 Ø230X21(FS35,FS40,FS50)
FS35-304	ZG-304-000037-0	Steel cable pulley (double groove) 2 Ø230X34(FS35,FS40,FS50)
FS35-305		Thread rod(FS35,FS40,FS50)
FS35-306	S-011-000011-3	spring ϕ 1.2* ϕ 12*60(FS35,FS40,FS50)
FS35-307	DG-3B4-001500-0	loading dock board roller(FS35,FS40,FS50)
FS35-308	ZZ-304-150000-Z	loading dock board(FS35)
FS40/FS50-308		loading dock board(FS40,FS50)
FS35-309	ZX-304-004100-0	loading dock board stationary shaft Ø10(FS35,FS40,FS50)
FS35-310	B-055-100001-0	shaft snap ring Ø10(FS35,FS40,FS50)
FS35-311	B-040-132425-1	flat washer Ø12(FS35,FS40,FS50)
FS35-312	B-050-120000-0	spring washer Ø12(FS35,FS40,FS50)
FS35-313	B-014-100251-1	hex bolt M10X25(FS35,FS40,FS50)
FS35-314	ZZ-304-003100-0	side sliding plate roller(FS35,FS40,FS50)
FS35-315	B-010-060351-1	hex socket head cap screw M6X35(half teeth) (FS35,FS40,FS50)
FS35-316	ZZ-304-050000-Z	side sliding plate (FS35,FS40,FS50)
FS35-317	ZZ-304-030000-Z	platform 1(FS35,FS40,FS50)
FS35-318	ZZ-304-060000-Z	Big cover plate 502x465x58mm(FS35,FS40,FS50)
FS35-319	ZZ-304-070000-Z	Small cover plate 502x210x48mm(FS35,FS40,FS50)
FS35-320	B-014-100201-1	hex bolt M10X20(FS35,FS40,FS50)
FS35-321	B-050-100000-0	spring washer Ø10(FS35,FS40,FS50)
FS35-322	B-040-112020-1	flat washer Ø10(FS35,FS40,FS50)
FS35-323	ZZ-304-002300-0	block car plate(FS35,FS40,FS50)
FS35-324	B-055-120001-0	shaft snap ring Ø12(FS35,FS40,FS50)
FS35-325	ZX-304-001200-0	steel cable limit shaft Ø12(FS35,FS40,FS50)
FS35-326	ZG-304-003500-0	Steel cable pulley (single groove) 3(FS35,FS40,FS50)
FS35-327	ZX-304-001400-0	Guide pulley stationary shaft (FS35)
FS40/FS50-327	ZX-304-001400-0	Guide pulley stationary shaft (FS40,FS50)

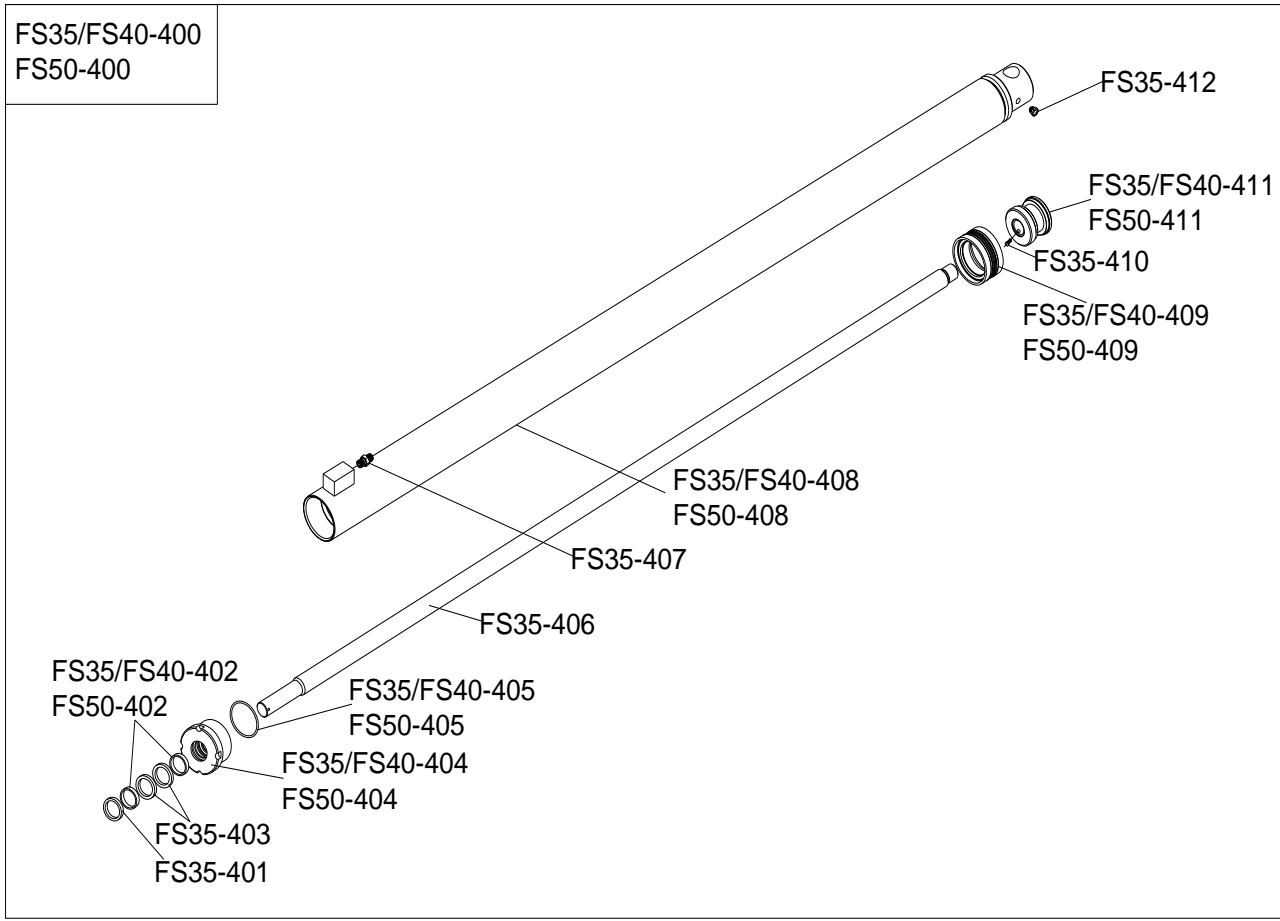

FS35-401	S-005-040065-0	dust-proof ring $\varnothing 32 \times 40 \times 6.5$ (FS35,FS40,FS50)
FS35-402	S-045-008025-0	wear ring(FS35,FS40)
FS50-402		wear ring(FS50)
FS35-403	S-006-042006-0	U-ring $\varnothing 32 \times 42 \times 6$ (FS35,FS40,FS50)
FS35-404	ZZ-304-160300-0	oil cylinder cover(FS35,FS40)
FS50-404		oil cylinder cover(FS50)
FS35-405	S-000-070004-0	O-ring $\varnothing 70 \times 4$ (FS35,FS40)
FS50-405		O-ring $\varnothing 75 \times 4$ (FS50)
FS35-406	ZZ-304-160200-1	piston rod(FS35,FS40,FS50)
FS35-407	S-011-010400-10	oil cylinder union(FS35,FS40,FS50)
FS35-408	ZZ-304-160100-Z	oil cylinder(FS35,FS40)
FS50-408		oil cylinder(FS50)
FS35-409	S-007-055224-0	combined seal ring $\varnothing 70 \times 50 \times 22.4$ (FS35,FS40)
FS50-409		combined seal ring $\varnothing 75 \times 55 \times 22.4$ (FS50)
FS35-410	B-007-060101-0	hex socket head cap screw M6X10(FS35,FS40,FS50)
FS35-411	ZZ-304-160100-0	piston (FS35,FS40)
FS50-411		piston (FS50)
FS35-412	S-023-010800-0	muffler G1/8(FS35,FS40,FS50)

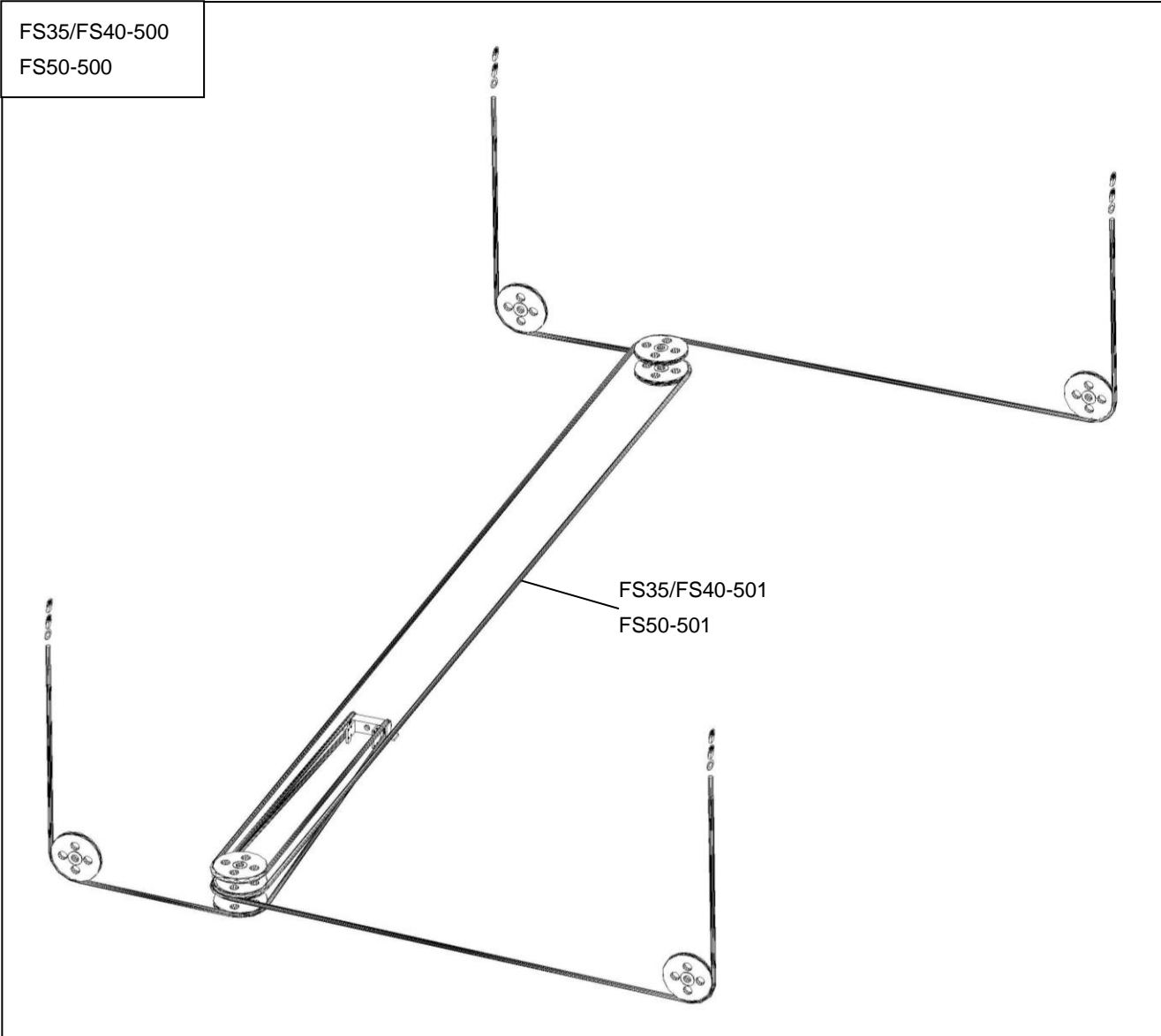

FS35/FS40-500		steel cable complete(FS35,FS40)
FS50-500		steel cable complete(FS50)
FS35/FS40-501	S-300-093000-1	steel cable (FS35,FS40)
FS50-501		steel cable (FS50)

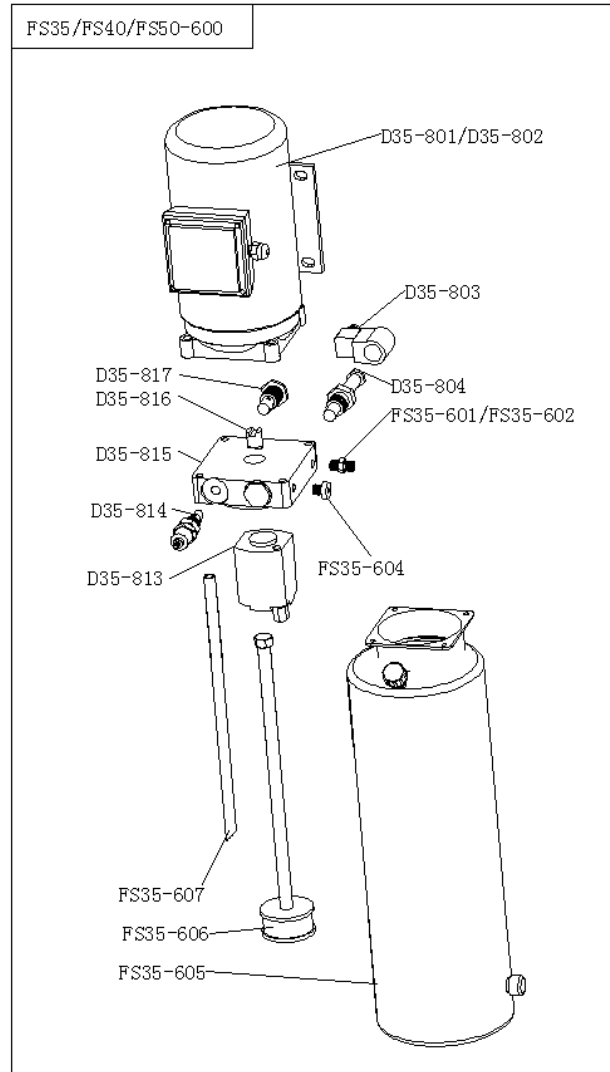

FS35-600	Complete power unit assembly(FS35,FS40,FS50)
D35-801	motor(FS35,FS40,FS50)
D35-816	annectent spindle(FS35,FS40,FS50)
D35-815	valve seat(FS35,FS40,FS50)
D35-814	overflow valve(FS35,FS40,FS50)
FS35-604	plug(FS35,FS40,FS50)
D35-817	one-way valve(FS35,FS40,FS50)
D35-813	gear pump(FS35,FS40,FS50)
FS35-605	oil tank(12L)(FS35,FS40,FS50)
FS35-606	extraction oil hose(FS35,FS40,FS50)
FS35-607	escape oil hose(FS35,FS40,FS50)
D35-803	coil(FS35,FS40,FS50)
D35-804	lowering valve(FS35,FS40,FS50)
FS35-601	hose fitting(FS35,FS40,FS50)



REACH
GARAGE EQUIPMENT

reachgarageequipment.com